

PEEK Flangeless Fittings —two-piece set

Features:

- Peek material, which insoluble in almost all solvents except concentrated sulfuric acid
- Superior to PTFE in terms of high temperature and abrasion resistance, high coefficient of friction and impact resistance
- High mechanical strength, fittings are not easily loosened after tightening
- Continuous operating temperature: -80°C~+250°C
- Can be disassembled repeatedly without affecting its sealing

★ Application Note

※ Ensure the end of tubing has a clean, square, burr-free cut.

Step 1. Slide the PEEK nut, followed by the ETFE ferrule, at least 3/16"(4.7625mm) from the end of clean cut tubing

Step 2. Insert the assembly into the receiving port, pushing the tubing into the port until it bottoms out

Step 3. Finger tighten the fittings into the port until snug

Step 4. After several uses (especially at high pressure) the ferrules should be replaced

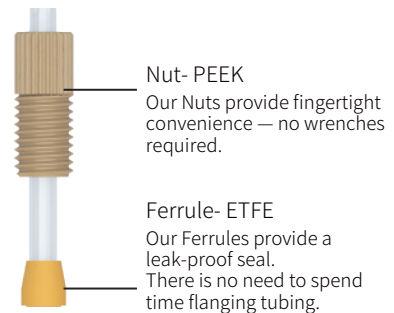

※ Make sure the ferrule is oriented correctly! The narrow end of the ferrule should towards the nut.

※ M6 threaded fittings support customization

Nut

Unit: mm

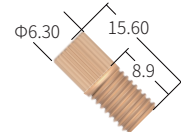

WF09B-1/4-28-K
For 1.6/2.0mm OD tube

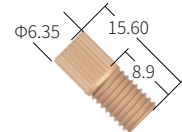

WF09B-M6-K
For 1.6/2.0mm OD tube

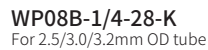

WP08B-1/4-28-K
For 2.5/3.0/3.2mm OD tube

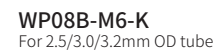

WP08B-M6-K
For 2.5/3.0/3.2mm OD tube

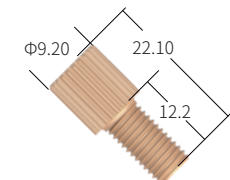

WF07B
For 1.6/2.0mm OD tube

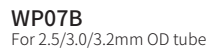

WP07B
For 2.5/3.0/3.2mm OD tube

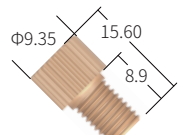

WF03B
For 1.6/2.0mm OD tube

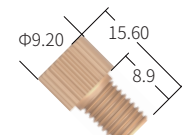

WD03B
For 2.5/3.0/3.2mm OD tube

Ferrule



YE-016-F
For 1.6mm OD tube
YE-020-F
For 2.0mm OD tube



YC-025-F
For 2.5mm OD tube
YC-030-F
For 3.0mm OD tube
YC-032-F
For 3.2mm OD tube

SKU	Model No.	Thread	Tube OD	Pressure Rating	Material
WF09B/WP08B					
1011010018	WF09B-1/4-28-K * YE-016-F	1/4-28UNF	1.6mm OD	3.4Mpa	PEEK natural * ETFE yellow
1011010017	WF09B-1/4-28-K * YE-020-F	1/4-28UNF	2.0mm OD	3.4Mpa	PEEK natural * ETFE yellow
1011010016	WP08B-1/4-28-K * YC-025-F	1/4-28UNF	2.5mm OD	3.4Mpa	PEEK natural * ETFE yellow
1011010015	WP08B-1/4-28-K * YC-030-F	1/4-28UNF	3.0mm OD	3.4Mpa	PEEK natural * ETFE yellow
1011010014	WP08B-1/4-28-K * YC-032-F	1/4-28UNF	3.2mm OD	3.4Mpa	PEEK natural * ETFE yellow
1011010050	WF09B-M6-K * YE-016-F	M6	1.6mm OD	3.4Mpa	PEEK natural * ETFE yellow
1011010051	WF09B-M6-K * YE-020-F	M6	2.0mm OD	3.4Mpa	PEEK natural * ETFE yellow
1011010052	WP08B-M6-K * YC-025-F	M6	2.5mm OD	3.4Mpa	PEEK natural * ETFE yellow
1011010053	WP08B-M6-K * YC-030-F	M6	3.0mm OD	3.4Mpa	PEEK natural * ETFE yellow
1011010054	WP08B-M6-K * YC-032-F	M6	3.2mm OD	3.4Mpa	PEEK natural * ETFE yellow
WF07B/WP07B					
1011010066	WF07B-1/4-28-K * YE-016-F	1/4-28UNF	1.6mm OD	3.4Mpa	PEEK natural * ETFE yellow
1011010067	WF07B-1/4-28-K * YE-020-F	1/4-28UNF	2.0mm OD	3.4Mpa	PEEK natural * ETFE yellow
1011010041	WP07B-1/4-28-K * YC-025-F	1/4-28UNF	2.5mm OD	3.4Mpa	PEEK natural * ETFE yellow
1011010042	WP07B-1/4-28-K * YC-030-F	1/4-28UNF	3.0mm OD	3.4Mpa	PEEK natural * ETFE yellow
1011010043	WP07B-1/4-28-K * YC-032-F	1/4-28UNF	3.2mm OD	3.4Mpa	PEEK natural * ETFE yellow
1011010039	WF07B-M6-K * YE-016-F	M6	1.6mm OD	3.4Mpa	PEEK natural * ETFE yellow
1011010040	WF07B-M6-K * YE-020-F	M6	2.0mm OD	3.4Mpa	PEEK natural * ETFE yellow
1011010063	WP07B-M6-K * YC-025-F	M6	2.5mm OD	3.4Mpa	PEEK natural * ETFE yellow
1011010064	WP07B-M6-K * YC-030-F	M6	3.0mm OD	3.4Mpa	PEEK natural * ETFE yellow
1011010065	WP07B-M6-K * YC-032-F	M6	3.2mm OD	3.4Mpa	PEEK natural * ETFE yellow
WF03B/WD03B					
1011010068	WF03B-1/4-28-K * YE-016-F	1/4-28UNF	1.6mm OD	3.4Mpa	PEEK natural * ETFE yellow
1011010069	WF03B-1/4-28-K * YE-020-F	1/4-28UNF	2.0mm OD	3.4Mpa	PEEK natural * ETFE yellow
1011010055	WD03B-1/4-28-K * YC-025-F	1/4-28UNF	2.5mm OD	3.4Mpa	PEEK natural * ETFE yellow
1011010056	WD03B-1/4-28-K * YC-030-F	1/4-28UNF	3.0mm OD	3.4Mpa	PEEK natural * ETFE yellow
1011010057	WD03B-1/4-28-K * YC-032-F	1/4-28UNF	3.2mm OD	3.4Mpa	PEEK natural * ETFE yellow
1011010078	WF03B-M6-K * YE-016-F	M6	1.6mm OD	3.4Mpa	PEEK natural * ETFE yellow
1011010079	WF03B-M6-K * YE-020-F	M6	2.0mm OD	3.4Mpa	PEEK natural * ETFE yellow
1011010058	WD03B-M6-K * YC-025-F	M6	2.5mm OD	3.4Mpa	PEEK natural * ETFE yellow
1011010059	WD03B-M6-K * YC-030-F	M6	3.0mm OD	3.4Mpa	PEEK natural * ETFE yellow
1011010060	WD03B-M6-K * YC-032-F	M6	3.2mm OD	3.4Mpa	PEEK natural * ETFE yellow

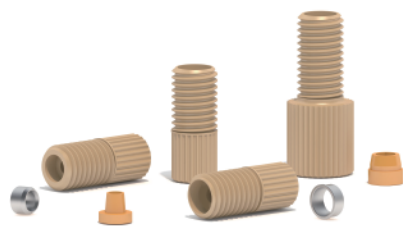

PEEK Flangeless Fittings —three-piece set

Features:

- With stainless steel lock ring, the rigid tube does not follow the rotation during screwing flangeless nut
- Continuous operating temperature: -80°C~+250°C
- Can be disassembled repeatedly without affecting its sealing
- Suitable for ion chromatography, genetic testing, high-end bioanalysis, experimental analytical instruments and other fields

Application Note

※ Ensure the end of tubing has a clean, square, burr-free cut.

Step 1. Slide the PEEK nut, followed by the 316 SST sleeve and ETFE ferrule, at least 3/16"(4.7625mm) from the end of clean cut tubing

Step 2. Insert the assembly into the receiving port, pushing the tubing into the port until it bottoms out

Step 3. Finger tighten the fittings into the port until snug

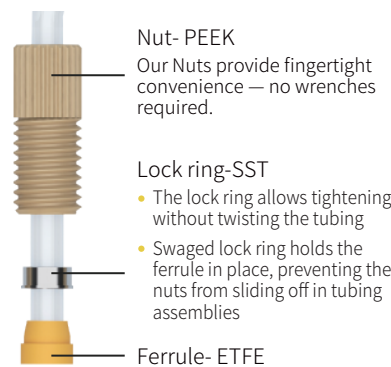

※ Make sure the locking ring is oriented correctly! The flattened end of the ring should face towards the nut with the narrow end of the ferrule towards the ring.

※ M6 threaded fittings support customization

SKU	Model No.	Thread	Tube OD	Pressure Rating	Material
WF01B/WD01B					
1011010009	WF01B-1/4-28-K * KCF-038-SUS316 * YE-016-F	1/4-28UNF	1.6mm OD	4.0Mpa	PEEK natural * SUS316 * ETFE yellow
1011010010	WF01B-1/4-28-K * KCF-038-SUS316 * YE-020-F	1/4-28UNF	2.0mm OD	4.0Mpa	PEEK natural * SUS316 * ETFE yellow
1011010011	WD01B-1/4-28-K * KCF-045-SUS316 * YK-025-F	1/4-28UNF	2.5mm OD	4.0Mpa	PEEK natural * SUS316 * ETFE yellow
1011010012	WD01B-1/4-28-K * KCF-045-SUS316 * YK-030-F	1/4-28UNF	3.0mm OD	4.0Mpa	PEEK natural * SUS316 * ETFE yellow
1011010013	WD01B-1/4-28-K * KCF-045-SUS316 * YK-032-F	1/4-28UNF	3.2mm OD	4.0Mpa	PEEK natural * SUS316 * ETFE yellow
1011010070	WF01B-M6-K * KCF-038-SUS316 * YE-016-F	M6	1.6mm OD	4.0Mpa	PEEK natural * SUS316 * ETFE yellow
1011010071	WF01B-M6-K * KCF-038-SUS316 * YE-020-F	M6	2.0mm OD	4.0Mpa	PEEK natural * SUS316 * ETFE yellow
WF06B/WD06B					
1011010031	WF06B-1/4-28-K * KCF-038-SUS316 * YE-016-F	1/4-28UNF	1.6mm OD	4.0Mpa	PEEK natural * SUS316 * ETFE yellow
1011010032	WF06B-1/4-28-K * KCF-038-SUS316 * YE-020-F	1/4-28UNF	2.0mm OD	4.0Mpa	PEEK natural * SUS316 * ETFE yellow
1011010033	WD06B-1/4-28-K * KCF-045-SUS316 * YK-025-F	1/4-28UNF	2.5mm OD	4.0Mpa	PEEK natural * SUS316 * ETFE yellow
1011010034	WD06B-1/4-28-K * KCF-045-SUS316 * YK-030-F	1/4-28UNF	3.0mm OD	4.0Mpa	PEEK natural * SUS316 * ETFE yellow
1011010035	WD06B-1/4-28-K * KCF-045-SUS316 * YK-032-F	1/4-28UNF	3.2mm OD	4.0Mpa	PEEK natural * SUS316 * ETFE yellow
1011010072	WF06B-M6-K * KCF-038-SUS316 * YE-016-F	M6	1.6mm OD	4.0Mpa	PEEK natural * SUS316 * ETFE yellow
1011010073	WF06B-M6-K * KCF-038-SUS316 * YE-020-F	M6	2.0mm OD	4.0Mpa	PEEK natural * SUS316 * ETFE yellow

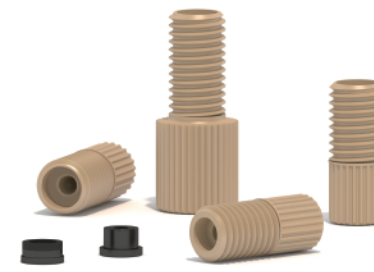
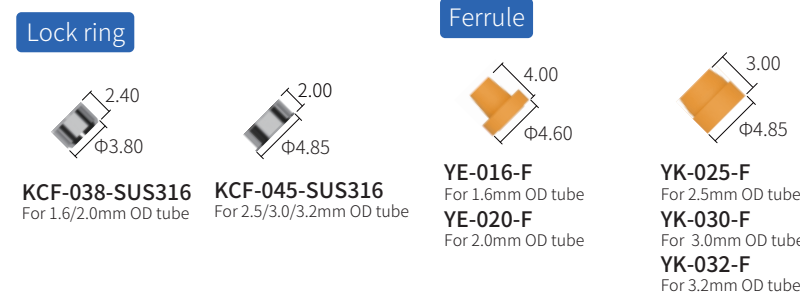
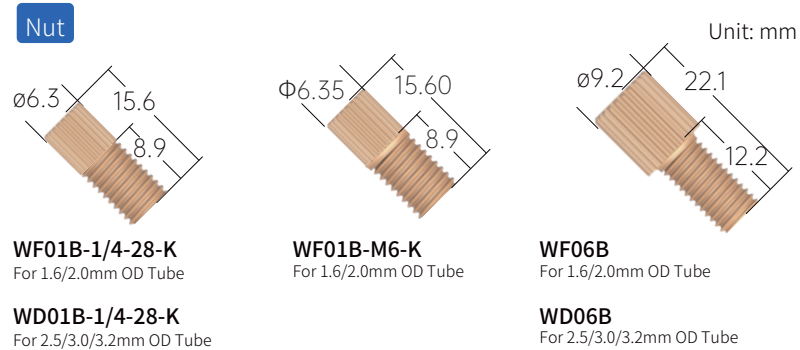

PEEK Flanged Fittings

Features:

- A traditional flat-bottomed fitting. By deforming the bottom of the tube, the bottom of the tube then compressed to form an airtight rigid tube connection system.
- Continuous operating temperature: -80°C to +250°C
- No change in tube diameter, no effect on flow rate, more stable flow rate
- Can be disassembled repeatedly without affecting its sealing

Application Note

※ Before flange the tubing, ensure the end of tubing has a clean, square, burr-free cut.

Step 1. Flange the tubing with exclusive flange tools, tubing can be flanged one end or both two ends, depending on specific application requirements

Step 2. When tubing flanged in two ends, 2 pieces clips and 2 pieces nuts need to be slid into the tubing before both ends flanged; when tubing flanged in one end, 1 piece clip and 1 piece nut can be slid into tubing before or after the one end flanged.

Step 3. Insert the assembly into the receiving port, pushing the tubing into the port until it bottoms out

Step 4. Finger tighten the fittings into the port until snug

Step 5. After several uses (especially at high pressure) the flanged tube should be replace

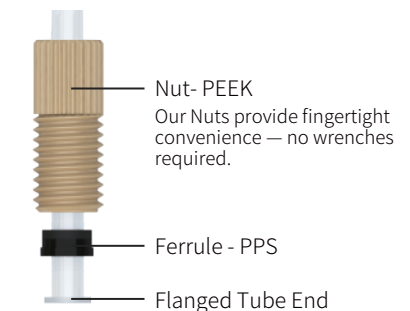

※ Make sure the ferrule is oriented correctly! The narrow end of the ferrule should towards the nut.

※ Flange the tubing with exclusive flange tools, flanged Tube End ≤ 5mm

※ M6 threaded fittings support customization

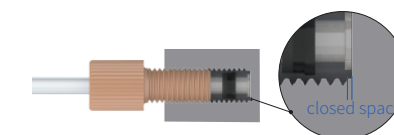
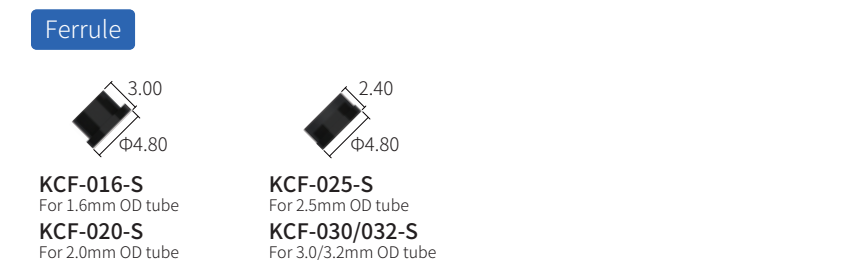
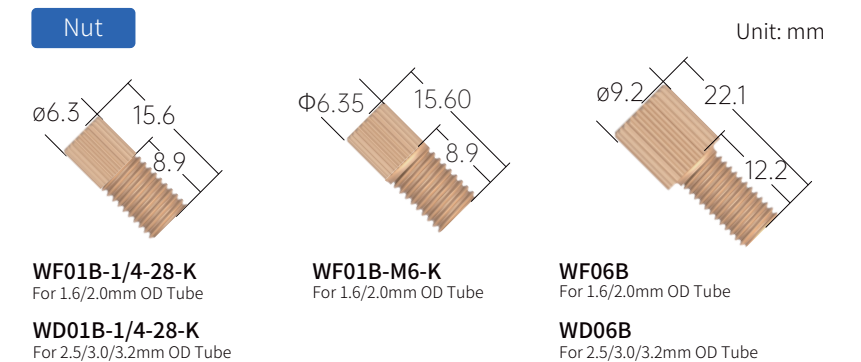

Note: Height of perforated closed space ≤ 0.5mm

SKU	Model No.	Thread	Tube OD	Material
WF01B/WD01B				
1011140011	WF01B-1/4-28-K * KCF-016-S	1/4-28UNF	1.6mm OD	PEEK natural * PPS black
1011140012	WF01B-1/4-28-K * KCF-020-S	1/4-28UNF	2.0mm OD	PEEK natural * PPS black
1011140013	WD01B-1/4-28-K * KCF-025-S	1/4-28UNF	2.5mm OD	PEEK natural * PPS black
1011140017	WD01B-1/4-28-K * KCF-030/032-S	1/4-28UNF	3.0mm/3.2mm OD	PEEK natural * PPS black
1011140019	WF01B-M6-K * KCF-016-S	M6	1.6mm OD	PEEK natural * PPS black
1011140020	WF01B-M6-K * KCF-020-S	M6	2.0mm OD	PEEK natural * PPS black
WF06B/WD06B				
1011140014	WF06B-1/4-28-K * KCF-016-S	1/4-28UNF	1.6mm OD	PEEK natural * PPS black
1011140015	WF06B-1/4-28-K * KCF-020-S	1/4-28UNF	2.0mm OD	PEEK natural * PPS black
1011140016	WD06B-1/4-28-K * KCF-025-S	1/4-28UNF	2.5mm OD	PEEK natural * PPS black
1011140018	WD06B-1/4-28-K * KCF-030/032-S	1/4-28UNF	3.0mm/3.2mm OD	PEEK natural * PPS black
1011140021	WF06B-M6-K * KCF-016-S	M6	1.6mm OD	PEEK natural * PPS black
1011140022	WF06B-M6-K * KCF-020-S	M6	2.0mm OD	PEEK natural * PPS black

PEEK One-Piece Fittings

Features:

- PEEK material, which insoluble in almost all solvents except concentrated sulfuric acid
- Superior to PTFE in terms of high temperature and abrasion resistance, high coefficient of friction and impact resistance
- High mechanical strength, fittings are not easily loosened after tightening
- Continuous operating temperature: -100°C~+250°C
- Original one-piece hand tightening fittings
- 10-32 threaded coned head for HPLC system application
- Suitable for 1.6 mm OD PEEK/PTFE/ETFE/FEP and other semi-rigid tubes

★ Application Note

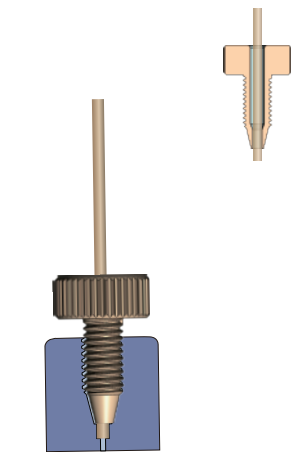

Nut

Unit: mm

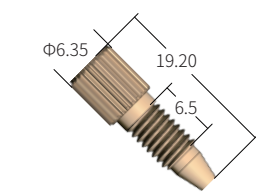

WK11A-10-32-K

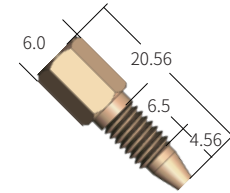

WK11E-10-32-K

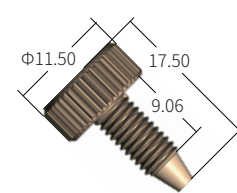

WK11C-10-32-K

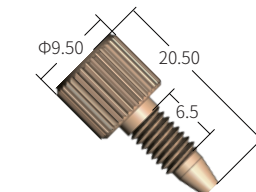

WK11G-10-32-K

Model No.	Thread	Tube OD	Pressure Rating	Material
WK11A-10-32-K	10-32UNF Coned	1.6mm OD	8.64Mpa	PEEK natural
WK11E-10-32-K	10-32UNF Coned	1.6mm OD	8.64Mpa	PEEK natural
WK11C-10-32-K	10-32UNF Coned	1.6mm OD	8.64Mpa	PEEK natural
WK11G-10-32-K	10-32UNF Coned	1.6mm OD	8.64Mpa	PEEK natural

Flangeless Fittings

Features:

- Resistant to chemicals and organics, including materials like PP, PTFE, POM, PPS
- Standard threads and curvature, no gap, no wobble and good sealing with the corresponding threads
- Available in five sizes of 1.6/2.0/2.5/3.0/3.2mm OD rigid tube, with a pressure capacity of 7 kg
- Quick and easy installation, no tools required, cost-effective



Application Note

※ Ensure the end of tubing has a clean, square, burr-free cut.

Step 1. Slide the nut, followed by the ferrule, at least 3/16" (4.7625mm) from the end of clean cut tubing

Step 2. Insert the assembly into the receiving port, pushing the tubing into the port until it bottoms out

Step 3. Finger tighten the fittings into the port until snug

Step 4. After disassembling, the ferrules should be replaced in next assembly and connection

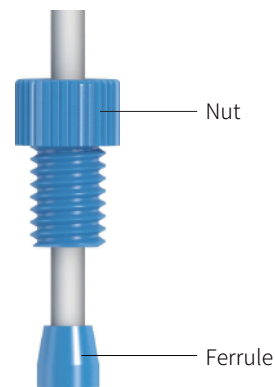

※ Make sure the ferrule is oriented correctly! The narrow end of the ferrule should towards the nut.

※ Flangeless nut is also available in PTFE and POM material Flangeless Fittings

Unit: mm

Nut

WF10A For 1.6/2.0mm OD tube **WD10A** For 2.5/3.0/3.2mm OD tube **WF03G** For 1.6/2.0mm OD tube **WD03G** For 2.5/3.0/3.2mm OD tube

WF08BL For 1.6/2.0mm OD tube **WD08BL** For 2.5/3.0/3.2mm OD tube **WF08B** For 1.6/2.0mm OD tube **WD08B** For 2.5/3.0/3.2mm OD tube

WF05EL For 1.6/2.0mm OD tube **WD05EL** For 2.5/3.0/3.2mm OD tube **WF05E** For 1.6/2.0mm OD tube **WD05E** For 2.5/3.0/3.2mm OD tube

WF06CL For 1.6/2.0mm OD tube **WD06CL** For 2.5/3.0/3.2mm OD tube **WF06C** For 1.6/2.0mm OD tube **WD06C** For 2.5/3.0/3.2mm OD tube

Ferrule

YE-016 For 1.6mm OD tube **YC-025** For 2.5mm OD tube
YE-020 For 2.0mm OD tube **YC-030** For 3.0mm OD tube
YC-032 For 3.2mm OD tube

SKU	Model No.	Thread	Tube OD	Material
WF10A/WD10A				
1006010170	WF10A-28P * YE-016P	1/4-28UNF	1.6mm OD	PP natural*PP natural
1006010169	WF10A-28P * YE-020P	1/4-28UNF	2.0mm OD	PP natural*PP natural
1006010168	WD10A-28P * YC-025P	1/4-28UNF	2.5mm OD	PP natural*PP natural
1006010167	WD10A-28P * YC-030P	1/4-28UNF	3.0mm OD	PP natural*PP natural
1006010166	WD10A-28P * YC-032P	1/4-28UNF	3.2mm OD	PP natural*PP natural
1006010175	WF10A-28E * YE-016A	1/4-28UNF	1.6mm OD	PTFE natural*PFA natural
1006010174	WF10A-28E * YE-020A	1/4-28UNF	2.0mm OD	PTFE natural*PFA natural
1006010173	WD10A-28E * YC-025A	1/4-28UNF	2.5mm OD	PTFE natural*PFA natural
1006010172	WD10A-28E * YC-030A	1/4-28UNF	3.0mm OD	PTFE natural*PFA natural
1006010171	WD10A-28E * YC-032A	1/4-28UNF	3.2mm OD	PTFE natural*PFA natural
1006010246	WF10A-M6P * YE-016P	M6	1.6mm OD	PP natural*PP natural
1006010247	WF10A-M6P * YE-020P	M6	2.0mm OD	PP natural*PP natural
1006010248	WD10A-M6P * YC-025P	M6	2.5mm OD	PP natural*PP natural
1006010249	WD10A-M6P * YC-030P	M6	3.0mm OD	PP natural*PP natural
1006010238	WD10A-M6P * YC-032P	M6	3.2mm OD	PP natural*PP natural
1006010241	WF10A-M6E * YE-016A	M6	1.6mm OD	PTFE natural*PFA natural
1006010242	WF10A-M6E * YE-020A	M6	2.0mm OD	PTFE natural*PFA natural
1006010243	WD10A-M6E+YC-025A	M6	2.5mm OD	PTFE natural*PFA natural
1006010244	WD10A-M6E+YC-030A	M6	3.0mm OD	PTFE natural*PFA natural
1006010245	WD10A-M6E+YC-032A	M6	3.2mm OD	PTFE natural*PFA natural

Model No.	Thread	Tube OD	Material
Nut			
WF03G-1/4-28-P	1/4-28UNF	1.6mm/2.0mm/OD	PP natural
WD03G-1/4-28-P	1/4-28UNF	2.5mm/3.0mm/3.2mm OD	PP natural
WF08BL-1/4-28-P	1/4-28UNF	1.6mm/2.0mm/OD	PP natural
WD08BL-1/4-28-P	1/4-28UNF	2.5mm/3.0mm/3.2mm OD	PP natural
WF08B-1/4-28-P	1/4-28UNF	1.6mm/2.0mm/OD	PP natural
WD08B-1/4-28-P	1/4-28UNF	2.5mm/3.0mm/3.2mm OD	PP natural
WF05EL-1/4-28-P	1/4-28UNF	1.6mm/2.0mm/OD	PP natural
WD05EL-1/4-28-P	1/4-28UNF	2.5mm/3.0mm/3.2mm OD	PP natural
WF05E-1/4-28-P	1/4-28UNF	1.6mm/2.0mm/OD	PP natural
WD05E-1/4-28-P	1/4-28UNF	2.5mm/3.0mm/3.2mm OD	PP natural
WF06CL-1/4-28-P	1/4-28UNF	1.6mm/2.0mm/OD	PP natural
WD06CL-1/4-28-P	1/4-28UNF	2.5mm/3.0mm/3.2mm OD	PP natural
WF06C-1/4-28-P	1/4-28UNF	1.6mm/2.0mm/OD	PP natural
WD06C-1/4-28-P	1/4-28UNF	2.5mm/3.0mm/3.2mm OD	PP natural
WF03G-06-P	M6	1.6mm/2.0mm/OD	PP natural
WD03G-06-P	M6	2.5mm/3.0mm/3.2mm OD	PP natural
WF08BL-06-P	M6	1.6mm/2.0mm/OD	PP natural
WD08BL-06-P	M6	2.5mm/3.0mm/3.2mm OD	PP natural
WF08B-06-P	M6	1.6mm/2.0mm/OD	PP natural
WD08B-06-P	M6	2.5mm/3.0mm/3.2mm OD	PP natural
WF05EL-06-P	M6	1.6mm/2.0mm/OD	PP natural
WD05EL-06-P	M6	2.5mm/3.0mm/3.2mm OD	PP natural
WF05E-06-P	M6	1.6mm/2.0mm/OD	PP natural
WD05E-06-P	M6	2.5mm/3.0mm/3.2mm OD	PP natural
WF06CL-06-P	M6	1.6mm/2.0mm/OD	PP natural
WD06CL-06-P	M6	2.5mm/3.0mm/3.2mm OD	PP natural
WF06C-06-P	M6	1.6mm/2.0mm/OD	PP natural
WD06C-06-P	M6	2.5mm/3.0mm/3.2mm OD	PP natural

Pre-torque Flangeless Fittings

Features:

- Working principle: Pre-applied forces to achieve a reliable and tight connection and to prevent gaps or relative slippage between the fittings after being applied force
- Resistant to chemical corrosion and various organic substances, including PTFE and PP materials
- Standard threads and curvature, no gap, no wobble and good sealing with the corresponding threads
- Used for standard rigid tubing OD 1.6/2.0/2.5/3.0/3.2mm, easy and fast installation.



Application Note

※ Ensure the end of tubing has a clean, square, burr-free cut.

Step 1. Slide the nut, followed by the ferrule, at least 3/16" (4.7625mm) from the end of clean cut tubing

Step 2. Insert the assembly into the receiving port, pushing the tubing into the port until it bottoms out

Step 3. Finger tighten the fittings into the port until snug

Step 4. After disassembling, the ferrules should be replaced in next assembly and connection

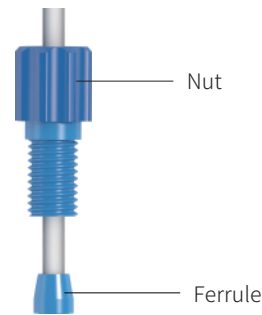

※ Make sure the ferrule is oriented correctly! The narrow end of the ferrule should towards the nut.

※ Please choose the correct nut model, so that no under-torque or over-torque will occur to affect tube sealing or squeeze tube.

※ Use environment: .
 0.11~0.15 N·m—WT ≤0.5mm at room temperature
 0.15~0.20 N·m—WT >0.5mm at room temperature
 0.20~0.25 N·m—Use temperature >100°C, or pressure >8kg

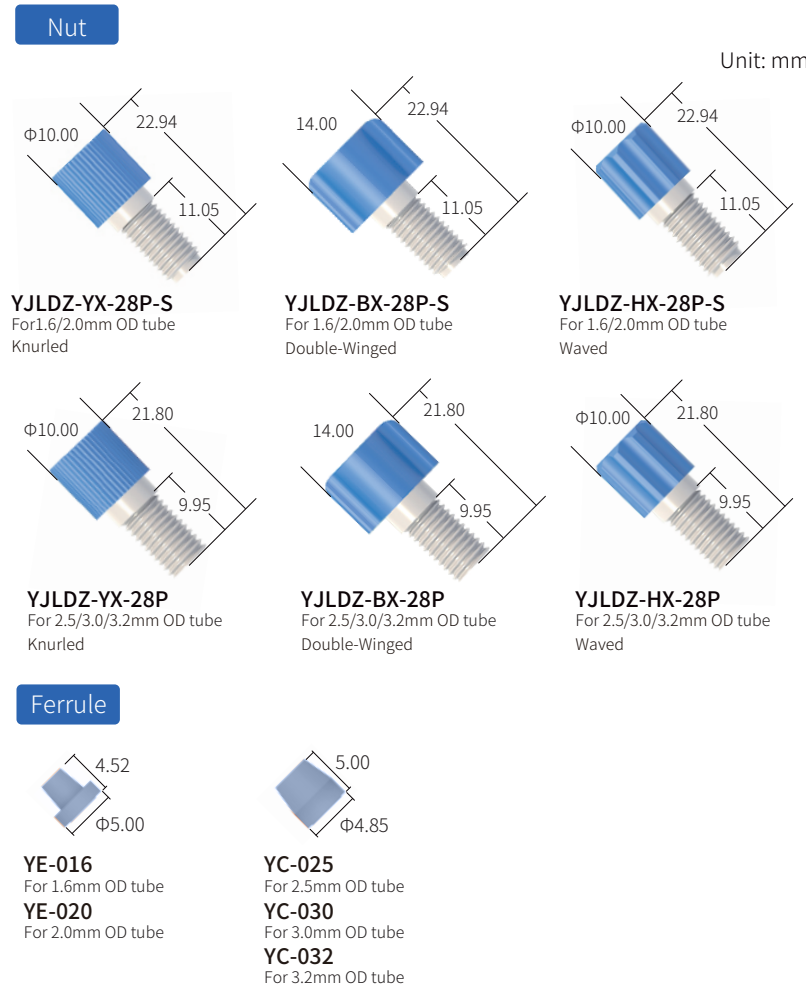

Model No.	Tube OD	Material
Ferrule		
YE-016-P	1.6mm OD	PP natural
YE-020-P	2.0mm OD	PP natural
YC-025-P	2.5mm OD	PP natural
YC-030-P	3.0mm OD	PP natural
YC-032-P	3.2mm OD	PP natural
YE-016-A	1.6mm OD	PFA natural
YE-020-A	2.0mm OD	PFA natural
YC-025-A	2.5mm OD	PFA natural
YC-030-A	3.0mm OD	PFA natural
YC-032-A	3.2mm OD	PFA natural

Model No.	Thread	Tube OD	Torque Range	Head Style	Material
Nut					
YJLDZ-YX-28P-S(011-015)	1/4-28UNF	1.6mm/2.0mm OD	0.11~0.15 N·m	Blue round screw head	PP natural
YJLDZ-YX-06P-S(011-015)	M6	1.6mm/2.0mm OD	0.11~0.15 N·m	Blue flat screw head	PP natural
YJLDZ-BX-28P-S(011-015)	1/4-28UNF	1.6mm/2.0mm OD	0.11~0.15 N·m	Blue flat screw head	PP natural
YJLDZ-BX-06P-S(011-015)	M6	1.6mm/2.0mm OD	0.11~0.15 N·m	Blue flat screw head	PP natural
YJLDZ-HX-28P-S(011-015)	1/4-28UNF	1.6mm/2.0mm OD	0.11~0.15 N·m	Blue flower-shaped screw head	PP natural
YJLDZ-HX-06P-S(011-015)	M6	1.6mm/2.0mm OD	0.11~0.15 N·m	Blue flower-shaped screw head	PP natural
YJLDZ-BX-28P-S(015-020)	1/4-28UNF	1.6mm/2.0mm OD	0.15~0.20 N·m	Yellow flat screw head	PP natural
YJLDZ-BX-06P-S(015-020)	M6	1.6mm/2.0mm OD	0.15~0.20 N·m	Yellow flat screw head	PP natural
YJLDZ-HX-28P-S(015-020)	1/4-28UNF	1.6mm/2.0mm OD	0.15~0.20 N·m	Yellow flower-shaped screw head	PP natural
YJLDZ-HX-06P-S(015-020)	M6	1.6mm/2.0mm OD	0.15~0.20 N·m	Yellow flower-shaped screw head	PP natural
YJLDZ-BX-28P-S(020-025)	1/4-28UNF	1.6mm/2.0mm OD	0.20~0.25 N·m	Red flat screw head	PP natural
YJLDZ-BX-06P-S(020-025)	M6	1.6mm/2.0mm OD	0.20~0.25 N·m	Red flat screw head	PP natural
YJLDZ-HX-28P-S(020-025)	1/4-28UNF	1.6mm/2.0mm OD	0.20~0.25 N·m	Red flower-shaped screw head	PP natural
YJLDZ-HX-06P-S(020-025)	M6	1.6mm/2.0mm OD	0.20~0.25 N·m	Red flower-shaped screw head	PP natural
YJLDZ-YX-28P-(011-015)	1/4-28UNF	2.5mm/3.0mm/3.2mm OD	0.11~0.15 N·m	Blue round screw head	PP natural
YJLDZ-YX-06P-(011-015)	M6	2.5mm/3.0mm/3.2mm OD	0.11~0.15 N·m	Blue round screw head	PP natural
YJLDZ-BX-28P-(011-015)	1/4-28UNF	2.5mm/3.0mm/3.2mm OD	0.11~0.15 N·m	Blue flat screw head	PP natural
YJLDZ-BX-06P-(011-015)	M6	2.5mm/3.0mm/3.2mm OD	0.11~0.15 N·m	Blue flat screw head	PP natural
YJLDZ-HX-28P-(011-015)	1/4-28UNF	2.5mm/3.0mm/3.2mm OD	0.11~0.15 N/m	Blue flower-shaped screw head	PP natural
YJLDZ-HX-06P-(011-015)	M6	2.5mm/3.0mm/3.2mm OD	0.11~0.15 N/m	Blue flower-shaped screw head	PP natural
YJLDZ-BX-28P-(015-020)	1/4-28UNF	2.5mm/3.0mm/3.2mm OD	0.15~0.20 N·m	Yellow flat screw head	PP natural
YJLDZ-BX-06P-(015-020)	M6	2.5mm/3.0mm/3.2mm OD	0.15~0.20 N·m	Yellow flat screw head	PP natural
YJLDZ-HX-28P-(015-020)	1/4-28UNF	2.5mm/3.0mm/3.2mm OD	0.15~0.20 N·m	Yellow flower-shaped screw head	PP natural
YJLDZ-HX-06P-(015-020)	M6	2.5mm/3.0mm/3.2mm OD	0.15~0.20 N·m	Yellow flower-shaped screw head	PP natural
YJLDZ-BX-28P-(020-025)	1/4-28UNF	2.5mm/3.0mm/3.2mm OD	0.20~0.25 N·m	Red flat screw head	PP natural
YJLDZ-BX-06P-(020-025)	M6	2.5mm/3.0mm/3.2mm OD	0.20~0.25 N·m	Red flat screw head	PP natural
YJLDZ-HX-28P-(020-025)	1/4-28UNF	2.5mm/3.0mm/3.2mm OD	0.20~0.25 N·m	Red flower-shaped screw head	PP natural
YJLDZ-HX-06P-(020-025)	M6	2.5mm/3.0mm/3.2mm OD	0.20~0.25 N·m	Red flower-shaped screw head	PP natural
YJLDZ-YX-28E-S(011-015)	1/4-28UNF	1.6mm/2.0mm OD	0.11~0.15 N·m	Blue round screw head	PTFE natural
YJLDZ-YX-06E-S(011-015)	M6	1.6mm/2.0mm OD	0.11~0.15 N·m	Blue round screw head	PTFE natural
YJLDZ-BX-28E-S(011-015)	1/4-28UNF	1.6mm/2.0mm OD	0.11~0.15 N·m	Blue flat screw head	PTFE natural
YJLDZ-BX-06E-S(011-015)	M6	1.6mm/2.0mm OD	0.11~0.15 N·m	Blue flat screw head	PTFE natural
YJLDZ-HX-28E-S(011-015)	1/4-28UNF	1.6mm/2.0mm OD	0.11~0.15 N·m	Blue flower-shaped screw head	PTFE natural
YJLDZ-HX-06E-S(011-015)	M6	1.6mm/2.0mm OD	0.11~0.15 N·m	Blue flower-shaped screw head	PTFE natural
YJLDZ-BX-28E-S(015-020)	1/4-28UNF	1.6mm/2.0mm OD	0.15~0.20 N·m	Yellow flat screw head	PTFE natural
YJLDZ-BX-06E-S(015-020)	M6	1.6mm/2.0mm OD	0.15~0.20 N·m	Yellow flat screw head	PTFE natural
YJLDZ-HX-28E-S(015-020)	1/4-28UNF	1.6mm/2.0mm OD	0.15~0.20 N·m	Yellow flower-shaped screw head	PTFE natural
YJLDZ-HX-06E-S(015-020)	M6	1.6mm/2.0mm OD	0.15~0.20 N·m	Yellow flower-shaped screw head	PTFE natural
YJLDZ-BX-28E-S(020-025)	1/4-28UNF	1.6mm/2.0mm OD	0.20~0.25 N·m	Red flat screw head	PTFE natural
YJLDZ-BX-06E-S(020-025)	M6	1.6mm/2.0mm OD	0.20~0.25 N·m	Red flat screw head	PTFE natural
YJLDZ-HX-28E-S(020-025)	1/4-28UNF	1.6mm/2.0mm OD	0.20~0.25 N·m	Red flower-shaped screw head	PTFE natural
YJLDZ-HX-06E-S(020-025)	M6	1.6mm/2.0mm OD	0.20~0.25 N·m	Red flower-shaped screw head	PTFE natural
YJLDZ-YX-28E-(011-015)	1/4-28UNF	2.5mm/3.0mm/3.2mm OD	0.11~0.15 N·m	Blue round screw head	PTFE natural
YJLDZ-YX-06E-(011-015)	M6	2.5mm/3.0mm/3.2mm OD	0.11~0.15 N·m	Blue round screw head	PTFE natural
YJLDZ-BX-28E-(011-015)	1/4-28UNF	2.5mm/3.0mm/3.2mm OD	0.11~0.15 N·m	Blue flat screw head	PTFE natural
YJLDZ-BX-06E-(011-015)	M6	2.5mm/3.0mm/3.2mm OD	0.11~0.15 N·m	Blue flat screw head	PTFE natural
YJLDZ-HX-28E-(011-015)	1/4-28UNF	2.5mm/3.0mm/3.2mm OD	0.11~0.15 N·m	Blue flower-shaped screw head	PTFE natural
YJLDZ-HX-06E-(011-015)	M6	2.5mm/3.0mm/3.2mm OD	0.11~0.15 N·m	Blue flower-shaped screw head	PTFE natural
YJLDZ-BX-28E-(015-020)	1/4-28UNF	2.5mm/3.0mm/3.2mm OD	0.15~0.20 N·m	Yellow flat screw head	PTFE natural
YJLDZ-BX-06E-(015-020)	M6	2.5mm/3.0mm/3.2mm OD	0.15~0.20 N·m	Yellow flat screw head	PTFE natural
YJLDZ-HX-28E-(015-020)	1/4-28UNF	2.5mm/3.0mm/3.2mm OD	0.15~0.20 N·m	Yellow flower-shaped screw head	PTFE natural
YJLDZ-HX-06E-(015-020)	M6	2.5mm/3.0mm/3.2mm OD	0.15~0.20 N·m	Yellow flower-shaped screw head	PTFE natural
YJLDZ-BX-28E-(020-025)	1/4-28UNF	2.5mm/3.0mm/3.2mm OD	0.20~0.25 N·m	Red flat screw head	PTFE natural
YJLDZ-BX-06E-(020-025)	M6	2.5mm/3.0mm/3.2mm OD	0.20~0.25 N·m	Red flat screw head	PTFE natural
YJLDZ-HX-28E-(020-025)	1/4-28UNF	2.5mm/3.0mm/3.2mm OD	0.20~0.25 N·m	Red flower-shaped screw head	PTFE natural
YJLDZ-HX-06E-(020-025)	M6	2.5mm/3.0mm/3.2mm OD	0.20~0.25 N·m	Red flower-shaped screw head	PTFE natural

Flanged Fittings

Features:

- The fitting requires a flat flanged end and a gasket/clip located between the flanged tube and the flat bottom fitting. Sealing achieved through tightening the nut, by deforming the bottom of the tube, the bottom of the tube then compressed to form an airtight rigid tube connection system. The wetted part is the tubing itself: a matching washer(gasket) is required.
- Resistant to chemicals and organics, including PP, PTFE, PPS and other materials
- Used for standard rigid tubing OD 1.6/2.0/2.5/3.0/3.2mm, easy and fast installation.
- Thread: 1/4-28UNF, M6

Application Note

※ Before flange the tubing, ensure the end of tubing has a clean, square, burr-free cut.

Step 1. Flange the tubing with exclusive flange tools, tubing can be flanged one end or both two ends, depending on specific application requirements

Step 2. When tubing flanged in two ends, 2 pieces clips and 2 pieces nuts need to be slid into the tubing before both ends flanged; when tubing flanged in one end, 1 piece clip and 1 piece nut can be slid into tubing before or after the one end flanged.

Step 3. Insert the assembly into the receiving port, pushing the tubing into the port until it bottoms out

Step 4. Finger tighten the fittings into the port until snug

Step 5. After several uses (especially at high pressure) the flanged tube should be replace

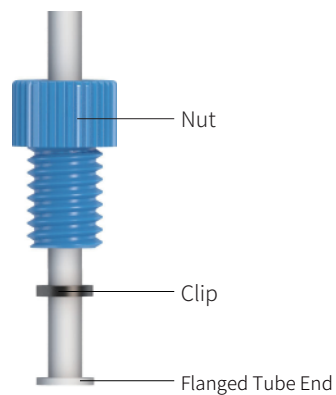

※ Flange the tubing with exclusive flange tools, flanged Tube End ≤ Φ5mm

※ Flangeless nut is also available in PTFE and POM material

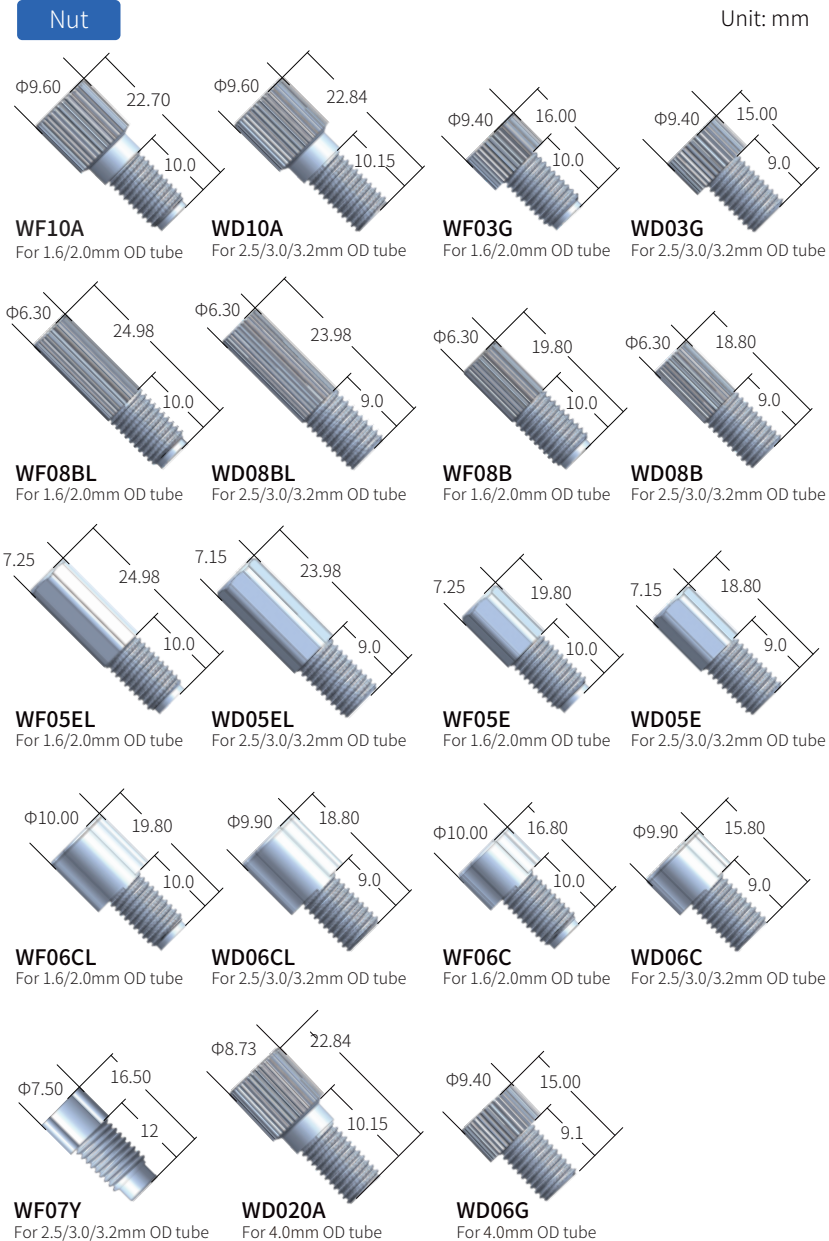

Clip

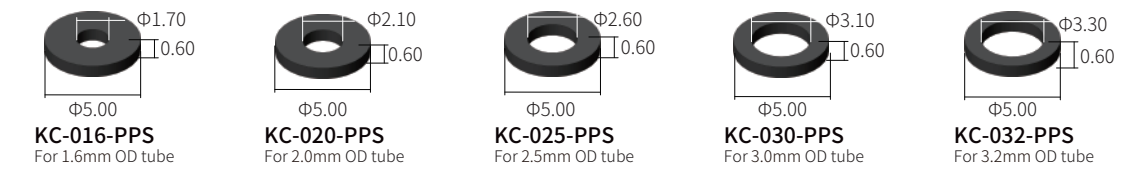

Model No.	Thread	Tube OD	Material
Nut			
WF10A-1/4-28-P	1/4-28UNF	1.6mm/2.0mm/OD	PP natural
WD10A-1/4-28-P	1/4-28UNF	2.5mm/3.0mm/3.2mm OD	PP natural
WF03G-1/4-28-P	1/4-28UNF	1.6mm/2.0mm/OD	PP natural
WD03G-1/4-28-P	1/4-28UNF	2.5mm/3.0mm/3.2mm OD	PP natural
WF08BL-1/4-28-P	1/4-28UNF	1.6mm/2.0mm/OD	PP natural
WD08BL-1/4-28-P	1/4-28UNF	2.5mm/3.0mm/3.2mm OD	PP natural
WF08B-1/4-28-P	1/4-28UNF	1.6mm/2.0mm/OD	PP natural
WD08B-1/4-28-P	1/4-28UNF	2.5mm/3.0mm/3.2mm OD	PP natural
WF05EL-1/4-28-P	1/4-28UNF	1.6mm/2.0mm/OD	PP natural
WD05EL-1/4-28-P	1/4-28UNF	2.5mm/3.0mm/3.2mm OD	PP natural
WF05E-1/4-28-P	1/4-28UNF	1.6mm/2.0mm/OD	PP natural
WD05E-1/4-28-P	1/4-28UNF	2.5mm/3.0mm/3.2mm OD	PP natural
WF06CL-1/4-28-P	1/4-28UNF	1.6mm/2.0mm/OD	PP natural
WD06CL-1/4-28-P	1/4-28UNF	2.5mm/3.0mm/3.2mm OD	PP natural
WF06C-1/4-28-P	1/4-28UNF	1.6mm/2.0mm/OD	PP natural
WD06C-1/4-28-P	1/4-28UNF	2.5mm/3.0mm/3.2mm OD	PP natural
WF07Y-1/4-28-P	1/4-28UNF	2.5mm/3.0mm/3.2mm OD	PP natural
WD020A-1/4-28-P	1/4-28UNF	4.0mm OD	PP natural
WD06G-1/4-28-P	M6	4.0mm OD	PP natural
WF10A-06-P	M6	1.6mm/2.0mm OD	PP natural
WD10A-06-P	M6	2.5mm/3.0mm/3.2mm OD	PP natural
WF03G-06-P	M6	1.6mm/2.0mm OD	PP natural
WD03G-06-P	M6	2.5mm/3.0mm/3.2mm OD	PP natural
WF08BL-06-P	M6	1.6mm/2.0mm OD	PP natural
WD08BL-06-P	M6	2.5mm/3.0mm/3.2mm OD	PP natural
WF08B-06-P	M6	1.6mm/2.0mm OD	PP natural
WD08B-06-P	M6	2.5mm/3.0mm/3.2mm OD	PP natural
WF05EL-06-P	M6	1.6mm/2.0mm OD	PP natural
WD05EL-06-P	M6	2.5mm/3.0mm/3.2mm OD	PP natural
WF05E-06-P	M6	1.6mm/2.0mm OD	PP natural
WD05E-06-P	M6	2.5mm/3.0mm/3.2mm OD	PP natural
WF06CL-06-P	M6	1.6mm/2.0mm OD	PP natural
WD06CL-06-P	M6	2.5mm/3.0mm/3.2mm OD	PP natural
WF06C-06-P	M6	1.6mm/2.0mm OD	PP natural
WD06C-06-P	M6	2.5mm/3.0mm/3.2mm OD	PP natural
WD020A-06-P	M6	4.0mm OD	PP natural
Clip			
KC-016-PPS		1.6mm OD	PPS black
KC-020-PPS		2.0mm OD	PPS black
KC-025-PPS		2.5mm OD	PPS black
KC-030-PPS		3.0mm OD	PPS black
KC-032-PPS		3.2mm OD	PPS black

Color Flangeless Fittings



Features:

- Different fitting colors for easy differentiation of flow paths
- Imported PP material, non-toxic, odorless, heat resistant, corrosion resistant, widely used in biological medicine, environmental protection, food industry
- Standard threads and curvature, no gap, no wobble and good sealing with the corresponding threads
- Available in five sizes of 1.6/2.0/2.5/3.0/3.2mm OD rigid tube, with a pressure capacity of 7 kg
- Quick and easy installation, no tools required, cost-effective

Application Note

Installation steps same as flangeless fittings

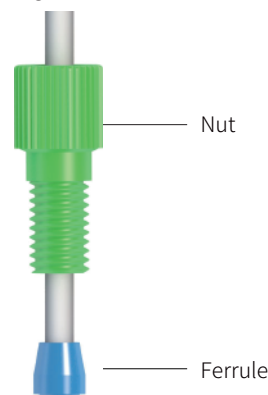

※ Make sure the ferrule is oriented correctly! The narrow end of the ferrule should towards the nut.

Nut

Unit: mm

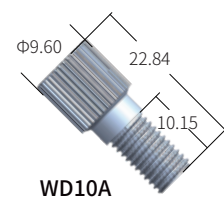

WD10A

Ferrule



YC-016
For 1.6mm OD tube
YC-020
For 2.0mm OD tube

YC-025
For 2.5mm OD tube
YC-030
For 3.0mm OD tube
YC-032
For 3.2mm OD tube

Model No.	Thread	Tube OD	Material
Nut			
WD10A-1/4-28-P-Red	1/4-28UNF	1.6mm/2.0mm/2.5mm/3.0mm/3.2mm OD	PP Red
WD10A-1/4-28-P-Dark Blue	1/4-28UNF	1.6mm/2.0mm/2.5mm/3.0mm/3.2mm OD	PP Dark Blue
WD10A-1/4-28-P-Beige Blue	1/4-28UNF	1.6mm/2.0mm/2.5mm/3.0mm/3.2mm OD	PP Beige Blue
WD10A-1/4-28-P-Deep Purple	1/4-28UNF	1.6mm/2.0mm/2.5mm/3.0mm/3.2mm OD	PP Deep Purple
WD10A-1/4-28-P-Lemon Yellow	1/4-28UNF	1.6mm/2.0mm/2.5mm/3.0mm/3.2mm OD	PP Lemon Yellow
WD10A-1/4-28-P-Dark Brown	1/4-28UNF	1.6mm/2.0mm/2.5mm/3.0mm/3.2mm OD	PP Dark Brown
WD10A-1/4-28-P-Grass Green	1/4-28UNF	1.6mm/2.0mm/2.5mm/3.0mm/3.2mm OD	PP Grass Green
WD10A-1/4-28-P-Deep Black	1/4-28UNF	1.6mm/2.0mm/2.5mm/3.0mm/3.2mm OD	PP Deep Black
WD10A-M6-P-Red	M6	1.6mm/2.0mm/2.5mm/3.0mm/3.2mm OD	PP Red
WD10A-M6-P-Dark Blue	M6	1.6mm/2.0mm/2.5mm/3.0mm/3.2mm OD	PP Dark Blue
WD10A-M6-P-Beige Blue	M6	1.6mm/2.0mm/2.5mm/3.0mm/3.2mm OD	PP Beige Blue
WD10A-M6-P-Deep Purple	M6	1.6mm/2.0mm/2.5mm/3.0mm/3.2mm OD	PP Deep Purple
WD10A-M6-P-Lemon Yellow	M6	1.6mm/2.0mm/2.5mm/3.0mm/3.2mm OD	PP Lemon Yellow
WD10A-M6-P-Dark Brown	M6	1.6mm/2.0mm/2.5mm/3.0mm/3.2mm OD	PP Dark Brown
WD10A-M6-P-Grass Green	M6	1.6mm/2.0mm/2.5mm/3.0mm/3.2mm OD	PP Grass Green
WD10A-M6-P-Deep Black	M6	1.6mm/2.0mm/2.5mm/3.0mm/3.2mm OD	PP Deep Black
WD10A-1/4-28-E-Red	1/4-28UNF	1.6mm/2.0mm/2.5mm/3.0mm/3.2mm OD	PTFE Red
WD10A-M6-E-Red	M6	1.6mm/2.0mm/2.5mm/3.0mm/3.2mm OD	PTFE Red
Ferrule			
YC-016-P		1.6mm OD	PP natural
YC-020-P		2.0mm OD	PP natural
YC-025-P		2.5mm OD	PP natural
YC-030-P		3.0mm OD	PP natural
YC-032-P		3.2mm OD	PP natural



Coned Plug

Features:

- For blocking the flow of liquids and gases
- Standard threads and curvature, no gap, no wobble and good sealing with the corresponding threads
- Imported raw material, non-toxic, tasteless, heat and corrosion resistant.
- PP material is widely used in biomedical, environmental protection and food industries; PTFE material is also suitable for chemical industry and other fields

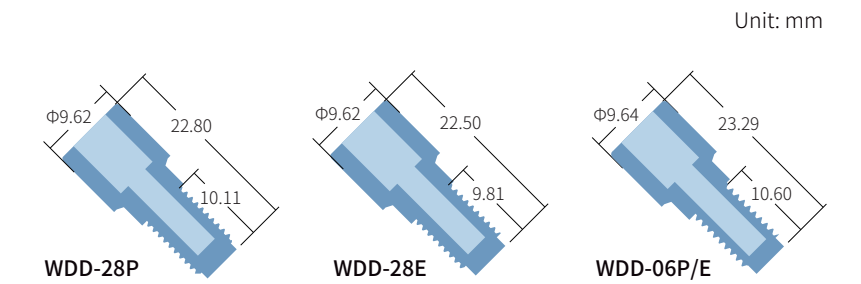

Model No.	Thread	Material
Coned Plug		
WDD-28P	1/4-28UNF	PP natural
WDD-28E	1/4-28UNF	PTFE natural
WDD-06P	M6	PP natural
WDD-06E	M6	PTFE natural



Female Thread Adapters

Features:

- Standard threads and curvature, no gap, no wobble and good sealing with the corresponding threads
- Imported raw material, non-toxic, tasteless, heat and corrosion resistant.
- PP material is widely used in biomedical, environmental protection and food industries; PTFE material is also suitable for chemical industry and other fields

Application Note

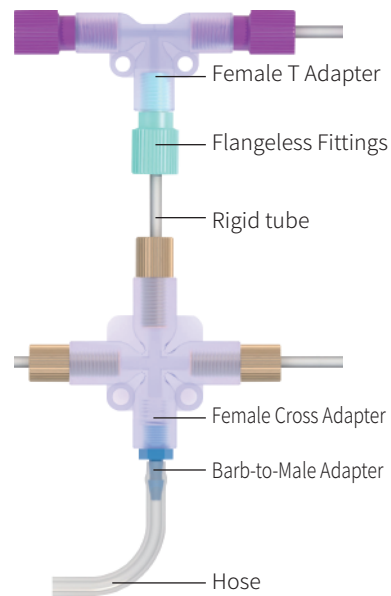

※ Can be connected to 1/4-28 UNF male threaded fittings to allow for any connection between rigid tube and rigid tube, rigid tube and hose, hose and hose of the same or different tube diameters

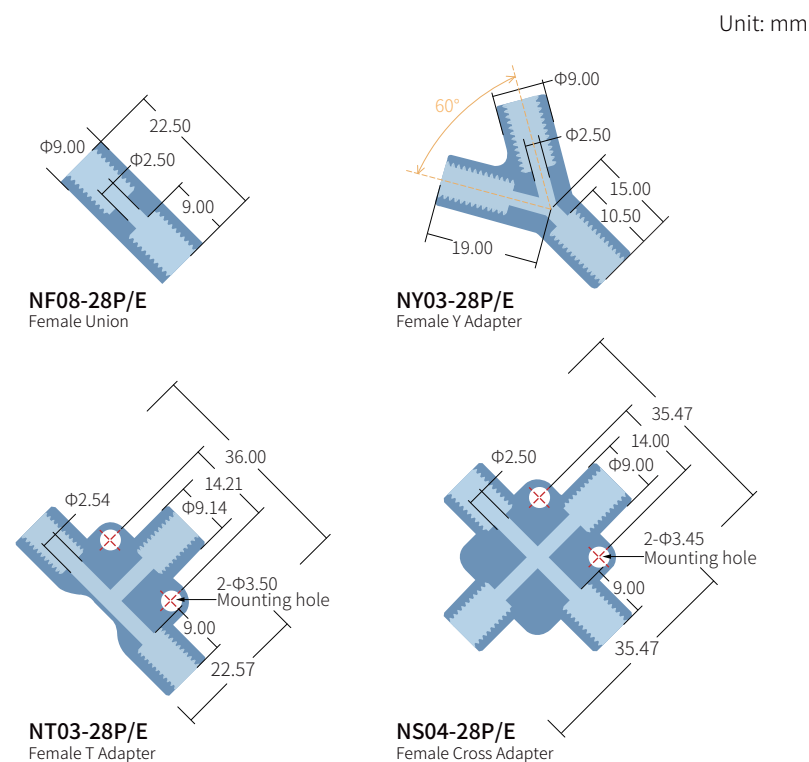

Model No.	Thread	Material
Female Union		
NF08-28P	1/4-28UNF female thread	PP natural
NF08-28E	1/4-28UNF female thread	PTFE natural
Female Y Adapter		
NY03-28P	1/4-28UNF female thread	PP natural
NY03-28E	1/4-28UNF female thread	PTFE natural
Female T Adapter		
NT03-28P	1/4-28UNF female thread	PP natural
NT03-28E	1/4-28UNF female thread	PTFE natural
Female Cross Adapter		
NS04-28P	1/4-28UNF female thread	PP natural
NS04-28E	1/4-28UNF female thread	PTFE natural



Low Pressure Male Union

Features:

- Standard threads and curvature, no gap, no wobble and good sealing with the corresponding threads
- The PPS material has high strength, high toughness, excellent heat and chemical resistance, good electrical property and inherent flame retardancy. The high strength and rigidity at high temperatures makes it a good load-bearing material.
- Suitable temperature range -50°C~150°C

Application Note

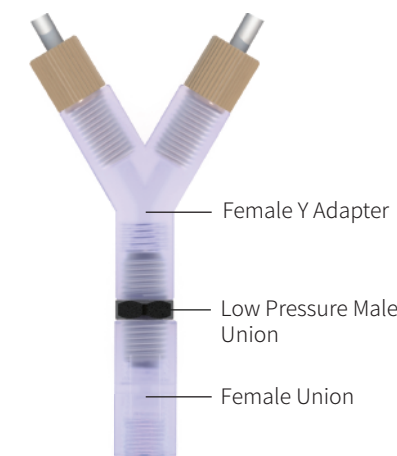

※ Can be used with RUNZE female threaded fittings and threaded bulkhead union to achieve connection of different tubes.

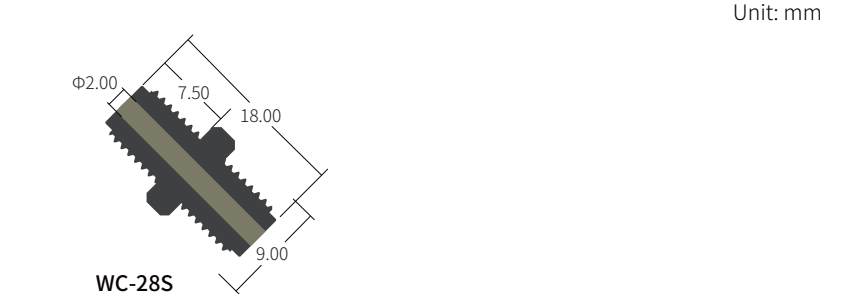

Model No.	Thread	Material
Low Pressure Male Union		
WC-28S	1/4-28UNF	PPS black

Bulkhead Two-piece Union

Features:

- Can be used RUNZE female threaded fittings and threaded bulkhead union to achieve connection of different tubes.
- Standard threads and curvature, no gap, no wobble and good sealing with the corresponding threads
- Imported raw material, non-toxic, tasteless, heat and corrosion resistant.
- PP material is widely used in biomedical, environmental protection and food industries; PTFE material is also suitable for chemical industry and other fields

Application Note

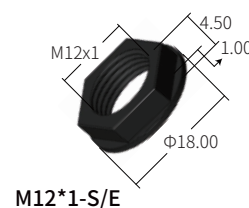
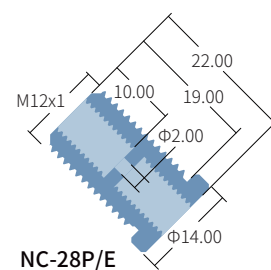
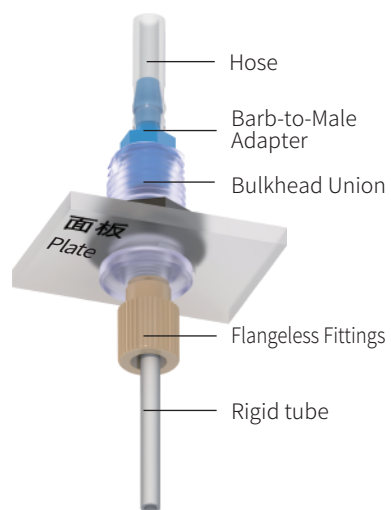

Unit: mm

※ Panel thickness ≤14mm

Thru-hole on panel

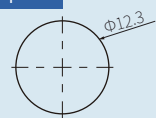

Unit: mm



Application Note

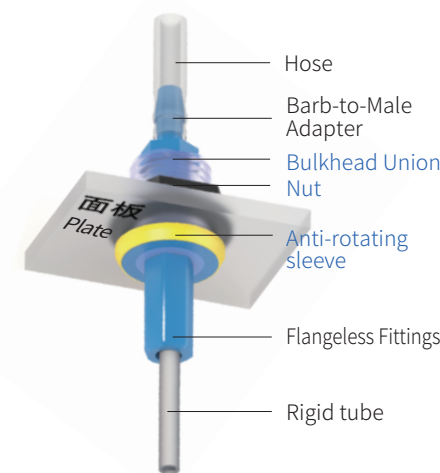

※ Panel thickness ≤9mm

Thru-hole on panel

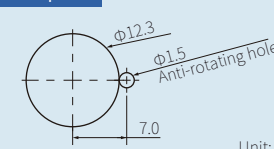

Unit: mm

Bulkhead Three-piece Union

Features:

- Anti-rotation sleeve has been added to prevent fitting from rotation
- Can be used with RUNZE male thread fitting, and threaded bulkhead union to realize rigid to rigid tubing, rigid tubing to hose, and hose to hose connections.
- Standard threads and curvature, no gap, no wobble and good sealing with the corresponding threads
- Imported raw material, non-toxic, tasteless, heat and corrosion resistant.
- PP material is widely used in biomedical, environmental protection and food industries; PTFE material is also suitable for chemical industry and other fields

Unit: mm

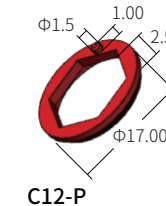
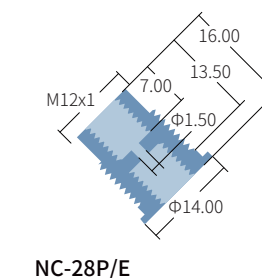

Model No.	Thread	Material
Bulkhead Union		
NC01-28P	1/4-28UNF female thread	PP natural
NC01-28E	1/4-28UNF female thread	PTFE natural
Nut		
M12*1-S		PPS black
M12*1-E		PTFE natural
Anti-rotating sleeve		
C12-P-Red		PP Red
C12-P-Black		PP Black
C12-P-Yellow		PP Yellow
C12-P-Green		PP Green
C12-P-Light Blue		PP Light Blue
C12-P-Dark Blue		PP Dark Blue
C12-P-Purple		PP Purple

SKU	Model No.	Thread	Material
Bulkhead Two-piece Union			
1006090041	NC-28P * M12*1-S	1/4-28UNF female thread	PP natural * PPS black
1006090042	NC-28P * M12*1-E	1/4-28UNF female thread	PP natura * PTFE natural
1006090043	NC-28E * M12*1-S	1/4-28UNF female thread	PTFE natural * PPS black
1006090044	NC-28E * M12*1-E	1/4-28UNF female thread	PTFE natural * PTFE natural