

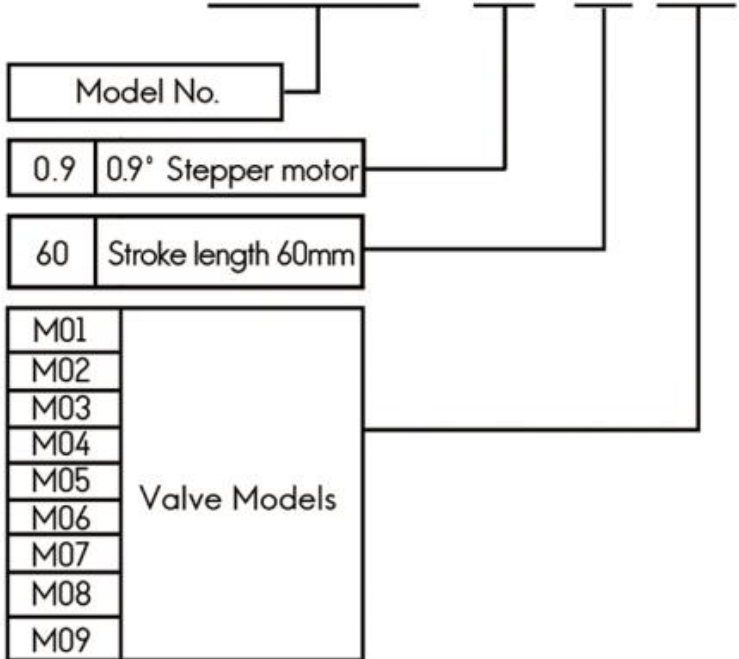



Model Number

ZSB - SY03 - 0.9 - 60 - M01



	ILS Syringe							RUNZE Syringe		
	25µl	50µl	100µl	250µl	500µl			1.18ml	2.45ml	5ml
1ml	1.25ml	2.5ml	5ml	10ml	25ml	10ml	25ml			

Valve Options



Valve Model M01
 Fluid Logic Y Flow Path (S-1/1-2/S-2 interlinked)
 Fluid Path PCTFE/Sapphire

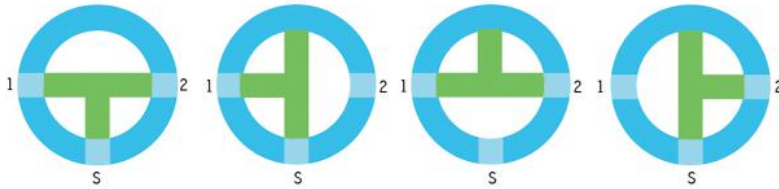

Valve Model M02
 Fluid Logic T Flow Path (S-1-2/S-1/1-2/S-2 interlinked)
 Fluid Path PCTFE/Sapphire

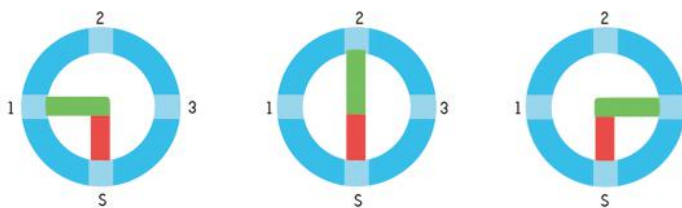

Valve Model M03
 Fluid Logic Distribution Flow Path (S-1/S-2/S-3 interlinked)
 Fluid Path PCTFE/Sapphire

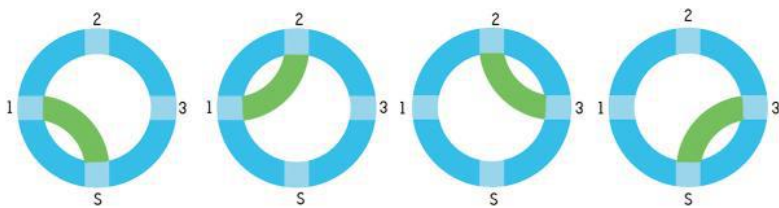

Valve Model M04
 Fluid Logic Radio Flow Path (S-1/1-2/2-3/S-3 interlinked)
 Fluid Path PCTFE/Sapphire

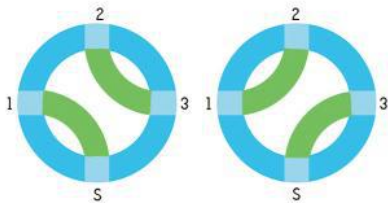

Valve Model M05
 Fluid Logic Bi-pass Flow Path
 (S-1/2-3 interlinked ; S-3/1-2 interlinked)
 Fluid Path PCTFE/Sapphire



Valve Model M06
 Fluid Logic Distribution Flow Path
 (S Port selectively link into port 1-6)
 Fluid Path PCTFE/Sapphire



Valve Model M07 (SY-03 M07)
 Fluid Logic Distribution Flow Path
 (S Port selectively link into port 1-8)
 Fluid Path PCTFE/Sapphire

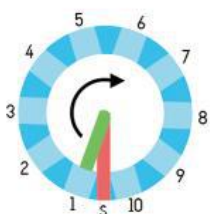

Valve Model M08
 Fluid Logic Distribution Flow Path
 (S Port selectively link into port 1-10)
 Fluid Path PCTFE/Sapphire

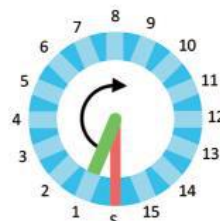

Valve Model M09
 Fluid Logic Distribution Flow Path
 (S Port selectively link into port 1-15)
 Fluid Path PCTFE/Sapphire

Dimension (unit: mm)



ZSB-SY03-1.8-60-M01.pdf



ZSB-SY03-1.8-60-M02.pdf



ZSB-SY03-1.8-60-M03.pdf



ZSB-SY03-1.8-60-M04.pdf



ZSB-SY03-1.8-60-M05.pdf



ZSB-SY03-1.8-60-M06.pdf



ZSB-SY03-1.8-60-M07.pdf



ZSB-SY03-1.8-60-M08.pdf

Syringe Assembly

1. When push rod moved to the bottom, loosen the thumb screw and disassembly the syringe counterclockwise.

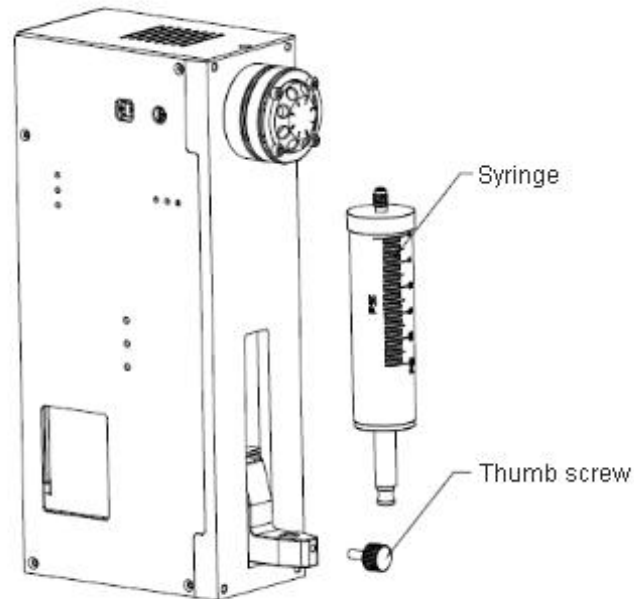

2. Clockwise assembly syringe into the thread mounting hole, pull piston push rod into the mounting hole of syringe push rod then tighten the thumb screw.

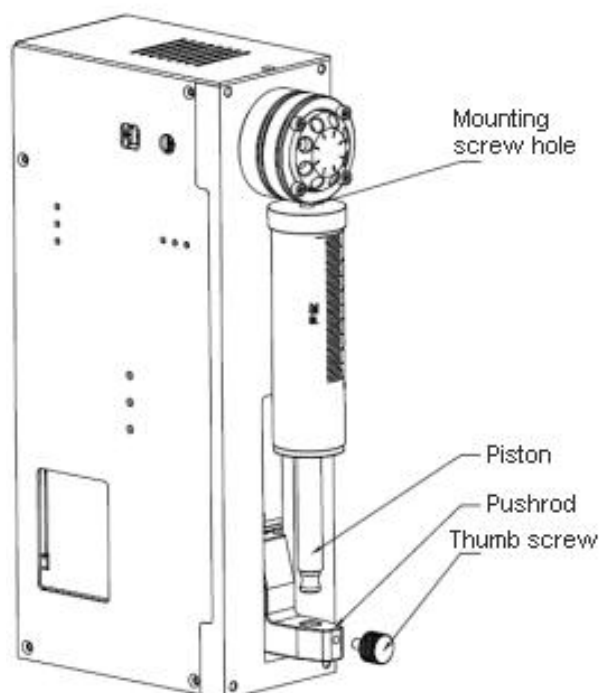

Technical Parameters

Model No.	SY-03
Accuracy	≤1%@100% stroke
Repeatability	3‰ - 5‰ (0.3% - 0.5%)
Rated stroke (control steps)	60mm (12000 steps/24000 steps/48000 steps)
Linear speed	0.017 – 5mm/s (media: water)
Time range (rated stroke)	12s – 3530s (media: water)
Service life	3 million times no leakage (media: water)
Resolution	0.005mm (1 step)
Actuator	Ball screw (lead 1mm)
Max. piston drive	≥ 80N
Sub. piston drive	≥ 40N
Syringe options	25μL 50μL 100μL 250μL 500μL 1ml 1.25ml 2.5ml 5ml 10ml 25ml
Valve options	M01 M02 M03 M04 M05 M06 M07 M08 M09
Valve switching time	≤280ms (switch from port to port)
Fluid path	Borosilicate cylinder, PTFE piston, PCTFE valve head, Sapphire valve spool
Max. pressure rating	0.7Mpa (water)
Connection	1/4-28UNF Female
Signal input	3-channel TTL signal input
Signal output	3-channel TTL signal output (for liquid detection); 3-channel DC24V power output (500mA) (for external solenoid valve control)
Communication	RS232/RS485/CAN
Baud rate	RS232/RS485: 9600dps, 19200dps, 38400dps, 57600dps, 115200dps CAN: 100K, 200K, 500K, 1M
Device address & Parameter setting	Communication interface
Power supply	DC24V/3A
Working environment	5°C– 55°C < 80% relative humidity, non-condensing
Dimension (L*W*H)	145*65*254mm
Net Weight	2.2kg

Sampling Resolution

E.g. SY-03 5ml syringe (stroke length 60mm)

5ml = 5000μl

60mm = 12000 steps

$5000\mu\text{l} \div 12000 \text{ steps} = 0.4167\mu\text{l}/\text{step}$

E.g. SY-03 5ml syringe pump dispense 3.8ml liquid, calculation as below:

3.8ml = 3800 μ l

3800 μ l \div 0.4167 μ l/step = 9119 steps (hexadecimal 239F)



RS232/RS485 Converter



Power Supply



U disk with debug software

Driver Port

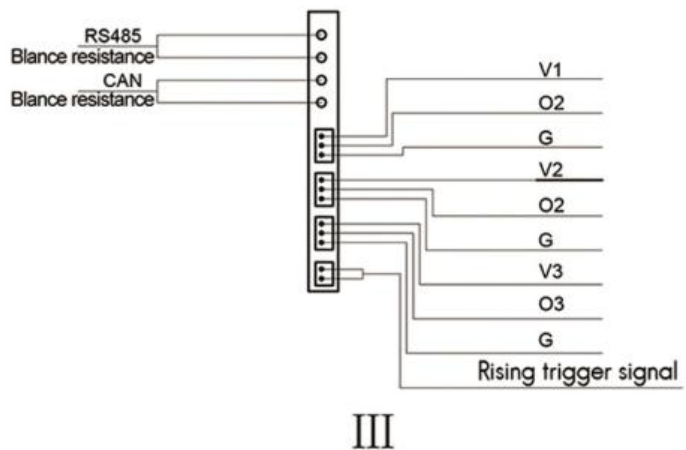
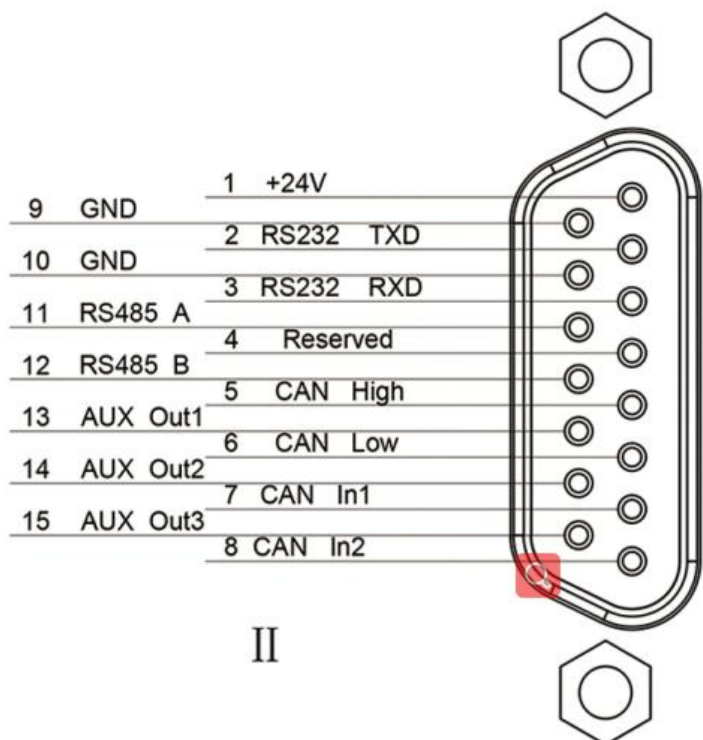
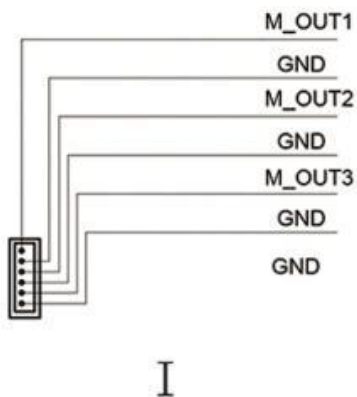
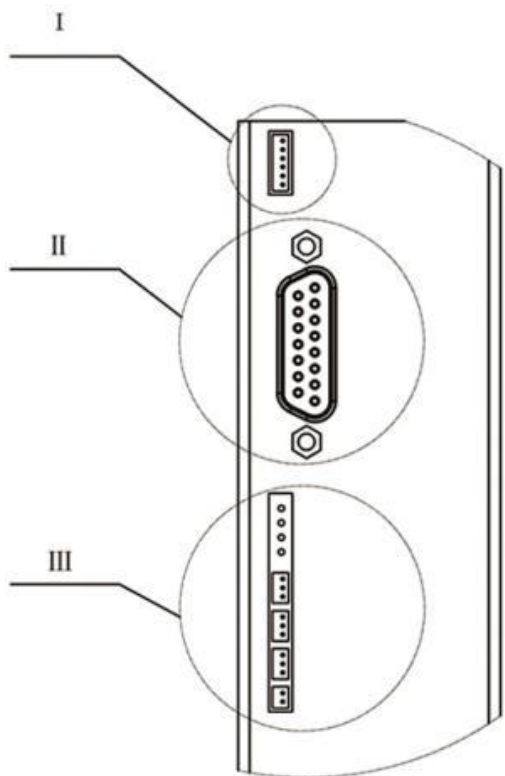

Wiring Direction

① Multi-device Parallel Connection

1. Set specific address for each device
2. Power supply must be properly chosen and connected, for laboratory linear power supply, please adjust the protection current to be higher than rated current of the device.
3. The jumper cap of RS485 or CAN must be short connected to ensure successful communication
4. Device address default as 00, baud rate default as 9600
5. Paralleling devices are recommend to be less than 20 sets, or users can use communication amplifier to strengthen the communication.

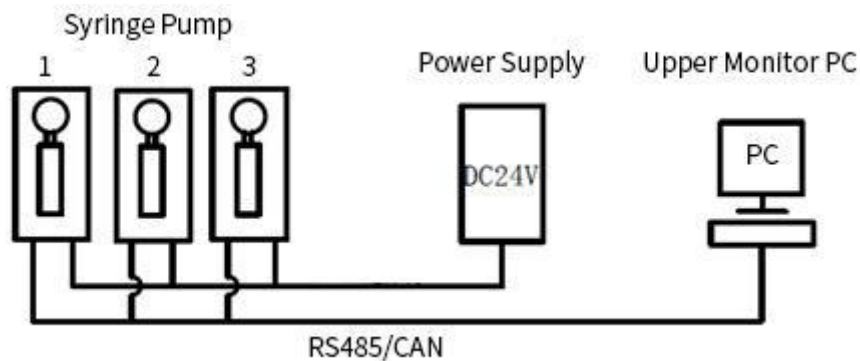

② Single-device Connection

1. Communication default address as 00, baud rate 9600
2. Please use correct power supply. If you use laboratory linear power supply, please adjust the protection current to make it higher than device rated current.

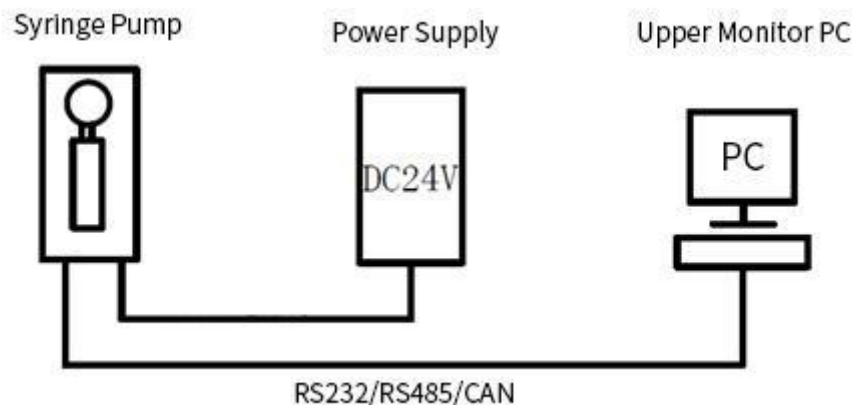

③ Device wire connection instruction

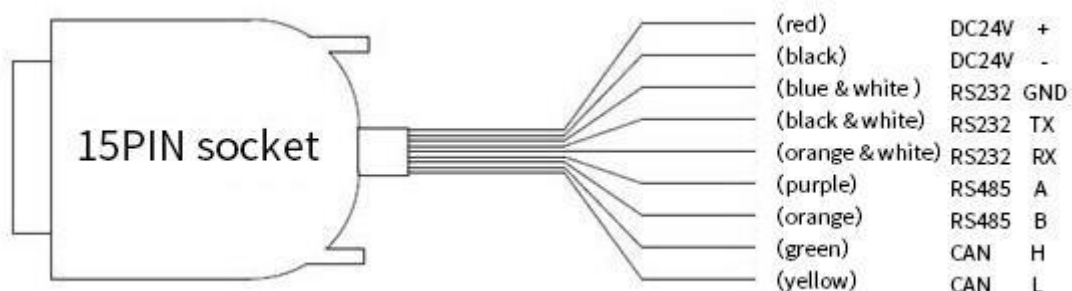

1. Switching power must be off when connect DC24V power supply into device (correct wiring +/-)
2. DC24V power supply must be off when connect communication wires
3. We ship wires for RS232, RS485, CAN, users need to pick one of them for specific application.

Driver Control Instruction

The data between syringe pump and upper monitor (PC, PLC, Raspberry Pi, micro-controller) was transmitted by serial communication RS232/RS485/CAN

Communication Form: Asynchronous serial communication; Command and data frames are sum check 2 Byte; Commands and data are hexadecimal numbers; Command parameters saved by little-endian mode.

Communication Interface: RS232 or RS485 or CAN

Communication Mode: Bidirectional asynchronous; master-slave mode

Baud rate: 9600bps,19200bps,38400bps,57600bps,115200bps (RS232/RS485) / 100K, 200K, 500K, 1M (CAN)

Data bit: 8

Even-odd Check: None

1. Control Command

Message frame of control command is 8 bytes, full format as following:

Common command	Start code	Address byte	Control command	Parameter	End code	Sum check
Byte position code	B0	B1	B2	B3, B4	B5	B6, B7
Byte content	0xCC	0x00~0xFF (Note 1)	Refer to Control Command List	Refer to Control Command List	0xDD	(Note 2)

Response Command

Common command	Start code	Address byte	Response command	parameter	End code	Sum check
Byte position code	B0	B1	B2	B3, B4	B5	B6, B7
Byte content	0xCC	0x00~0xFF (Note 5)	Refer to Control Command List	Refer to Control Command List	0xDD	(Note 2)

Note 1 Address default as 0x00

Note 2 Sum check = data sum from start code to end code.

All code parameters saved by little-endian mode. Little-endian mode means low data position saved in the low address, high data position saved in the high address.

Note 3 B3-B6 = 0xaabbef (hexadecimal), little-endian saved as B3=0xff, B4=0xee, B5=0xbb, B6=0xaa

Note 4 Response command format of common command and factory command are the same.

Note 5 Address position of response command same as send command (common and factory command)

Control Command List

Command code (B2)	Function	Parameter (B3,B4)	Response Command (B2)	When response command B2=0x00 B3B4 as below
0x42	Motor moves as CW (Injection), motor stops when touch reset Optocoupler	1-20000 0x0001~0x4e20	B2=0x00 Normal status B2=0x01 Frame error B2=0x02 Parameter error B2=0x03 Optocoupler error B2=0x04 Motor busy B2=0x05 Motor stalling B2=0x06 Unknown position B2=0xfe Task suspension B2=0xff Unknown error	B3B4=0x0000
0x43	Motor moves as CCW (Suction), motor stops when touch nether limit Optocoupler	1-20000 0x0001~0x4e20		B3B4=0x0000
0x44	Valve runs by coded disc and auto-select best path	1-maximum port number	Note: B2=0xFE will only appears in RS485, at this moment you can only get response command by send polling command 0x4A or 0x4D	Internal data B3B4 (random occurrence)
0x45	Pump reset	0x0000		Internal data B3B4 (random occurrence)
0x49	Strong stop (pump+valve)	0x0000	B2=0x00 Normal status B2=0x01 Frame error B2=0x02 Parameter error B2=0x03 Optocoupler error B2=0x04 Motor busy B2=0x05 Motor stalling B2=0x06 Unknown position B2=0xfe Task suspension B2=0xff Unknown error	B3B4=0x0000
0x4b	Dynamically speed setting	1-255(B) 1-300(C)		B3B4=0x0000
0x4c	Valve reset	0x0000	B2=0x00 Normal status B2=0x01 Frame error B2=0x02 Parameter error B2=0x03 Optocoupler error B2=0x04 Motor busy B2=0x05 Motor stalling B2=0x06 Unknown position B2=0xfe Task suspension B2=0xff Unknown error Note: B2=0xFE will only appears in RS485, at this moment you can only get response command by send polling command 0x4A or 0x4D	Internal data B3B4 (random occurrence)
0x60	MOS open (MOS =24v power supply)	0x0001 or 0x0002 or 0x0003 or	B2=0x00 Normal status B2=0x01 Frame error B2=0x02 Parameter error B2=0x03 Optocoupler error B2=0x04 Motor busy B2=0x05 Motor blocked B2=0x06 Unknown position B2=0xfe Task suspension B2=0xff Unknown error	B3B4=0x0000
0x61	MOS close (MOS =24v power supply)	0x0001 or 0x0002 or 0x0003 or		B3B4=0x0000
0x66	Read piston position	0x0000		B3B4 = steps from current piston position to reset position

0x67	Clear piston position	0x0000	B3B4=0x0000
------	-----------------------	--------	-------------

Note: After reset syringe pump, please reset origin with command 0x67 to ensure command 0x66 will read accurate piston position.

2. Operation Examples

E.g.1 Syringe pump runs as clockwise and stops when touching reset optocoupler

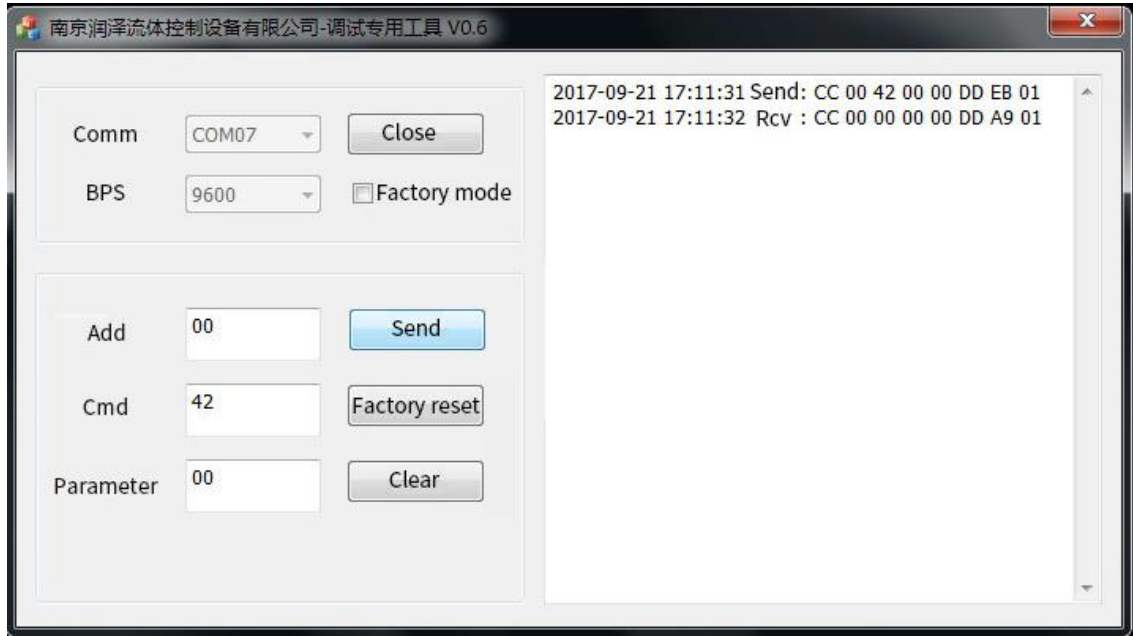

E.g.2 Valve switches via coded disc and auto-select optimal path

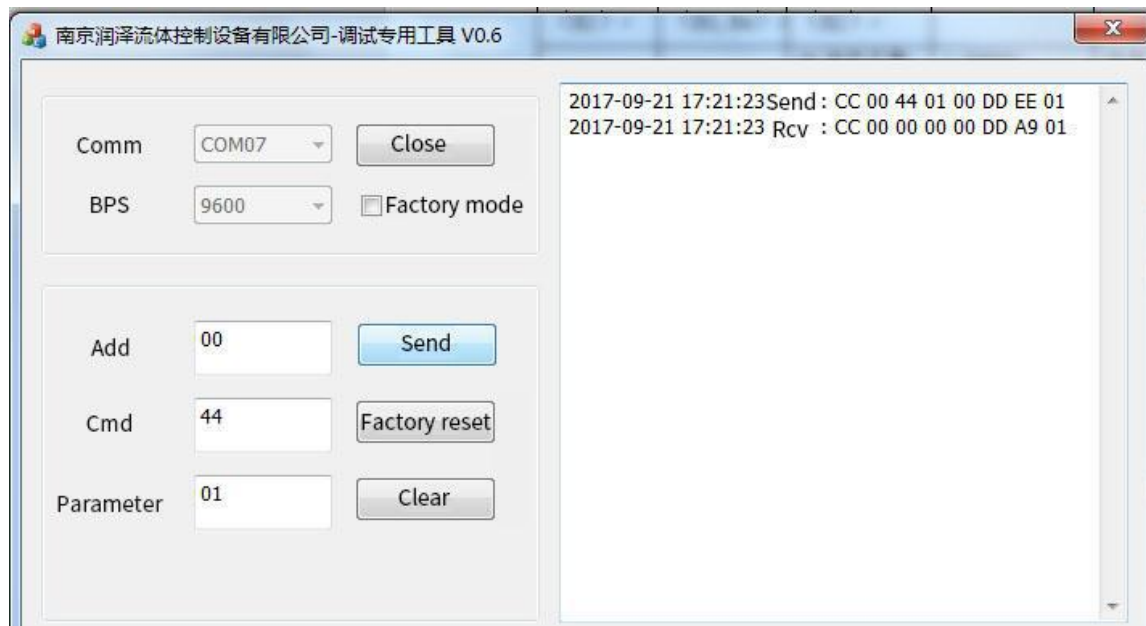

3. Query Command

Message frame of query command is 8 bytes, full format as following:

Common command	Start code	Address byte	Control command	Parameter	End code	Sum check
Byte position code	B0	B1	B2	B3, B4	B5	B6, B7
Byte content	0xCC	0x00~0xFF (Note 1)	Refer to Query Command List	0x0000	0xDD	(Note 2)

Response Command

Common command	Start code	Address byte	Response command	Parameter	End code	Sum check
Byte position code	B0	B1	B2	B3, B4	B5	B6, B7
Byte content	0xCC	0x00~0xFF (Note 5)	Refer to Query Command List	Refer to Query Command List	0xDD	(Note 2)

Query Command List (Address default as hexadecimal 00)

Command code (B2)	Function	Response Command (B2)	When response command B2=0x00 B3B4 as below
0x20	Query address		B3B4 = Device address (0x0000~0x00FF)
0x21	Query RS232 baud rate	B2=0x00 Normal status B2=0x01 Frame error B2=0x02 Parameter error B2=0x03 Optocoupler error B2=0x04 Motor busy B2=0x05 Motor stalling B2=0xfe Task suspension B2=0xff Unknown error	RS232 baud rate as below: B3B4=0x0000 9600bps B3B4=0x0001 19200bps B3B4=0x0002 38400bps B3B4=0x0003 57600bps B3B4=0x0004 115200bps
0x22	Query RS485 baud rate		RS485 baud rate as below: B3B4=0x0000 9600bps B3B4=0x0001 19200bps B3B4=0x0002 38400bps B3B4=0x0003 57600bps B3B4=0x0004 115200bps
0x23	Query CAN baud rate		CAN baud rate as below: B3B4=0x0000 100Kbps B3B4=0x0001 200Kbps B3B4=0x0002 500Kbps B3B4=0x0003 1Mbps
0x27	Query maximum speed		B3B4 = Max. speed
0x2b	Query reset speed		B3B4 = Reset speed
0x30	Query CAN destination address		B3B4 = CAN destination address (0x0000~0x00FF)

0x4a	Query pump status (0X4a is roll polling command in RS485)	B2=0x00 normal status B2=0x01 frame error B2=0x02 parameter error B2=0x03 optocoupler error B2=0X04 motor busy B2=0x05 motor blocked B2=0xff unknown error	When query 00x42\0x43\0x44\0x45 in RS485, received code FE means command received and operating.
0x65	Query pump stop events	B2=0x00 normal status B2=0x01 frame error B2=0x02 parameter error B2=0x03 optocoupler error B2=0X04 motor busy B2=0x05 motor blocked B2=0xfe task suspension B2=0xff unknown error	B3B4=0x0000 Unknown reason B3B4=0x0001 Motor run the steps as command told B3B4=0x0002 Motor stops when touch Optocoupler B3B4=0x0003 Coded disc detected motor stalling B3B4=0x0004 Internal chips detected motor stalling B3B4=0x0005 External event request motor stop
0x66	Query current motor position		
0x68	Query motor direction	B2=0x00 Normal status B2=0x01 Frame error B2=0x02 Parameter error B2=0x03 Optocoupler error B2=0X04 Motor busy B2=0x05 Motor stalling B2=0xfe Task suspension B2=0xff Unknown error	B3B4=0x0000 or B3B4=0x0001
0x4d	Query valve status (0X4d is roll polling command in RS485)	B2=0x00 Normal status B2=0x01 Frame error B2=0x02 Parameter error B2=0x03 Optocoupler error B2=0X04 Motor busy B2=0x05 Motor stalling B2=0xff Unknown error	B3B4 = Rest steps of valve, When query 00x42\0x43\0x44\0x45 in RS485, received code FE means command received and operating.
0x94	Query valve working current	B2=0x00 Normal status B2=0x01 Frame error B2=0x02 Parameter error B2=0x03 Optocoupler error B2=0X04 Motor busy B2=0x05 Motor stalling B2=0xfe Task suspension B2=0xff Unknown error	B3B4 = current value (Refer to below "Current Table")

4. Operation Examples

E.g.1 Query maximum speed

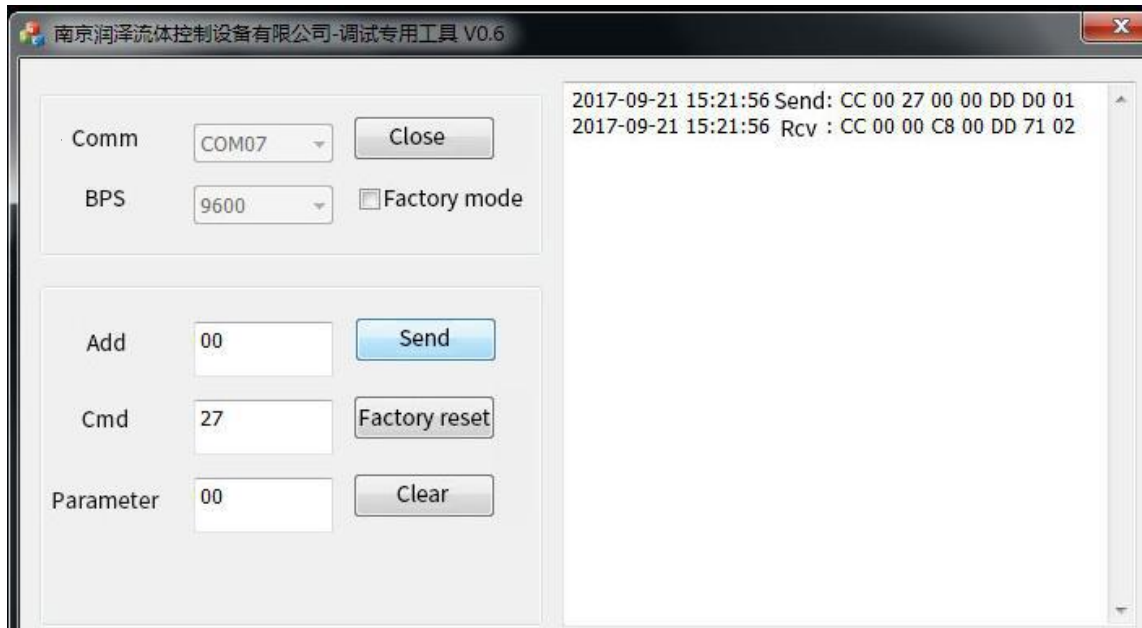

E.g.2 Query valve working current

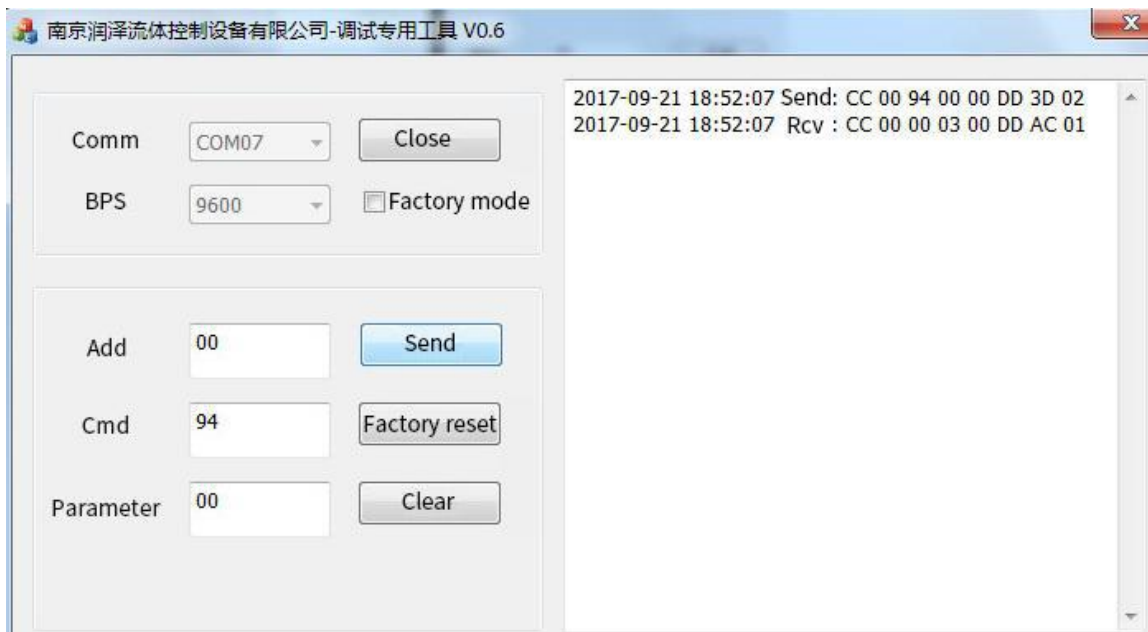

5. Factory Command

Message frame of Factory Command is 14 bytes, full format as following:

Factory command	Start code	Address byte	Control command	Password	Parameter	End code	Sum check
Byte position code	B0	B1	B2	B3~B6	B7~B10	B11	B12,B13

Byte content	0xCC	0x00~0xFF	Refer to Factory Command List	0xaabbfeff (Note 3)	Refer to Factory Command List	0xDD	(Note 2)
--------------	------	-----------	-------------------------------	---------------------	-------------------------------	------	----------

Response Command

Response Frame	Start code	Address byte	Response Command	parameter	End code	Sum check
Byte position code	B0	B1	B2	B3, B4	B5	B6, B7
Byte content	0xCC	0x00~0xFF (Note 5)	Refer to Factory Command List	0x0000	0xDD	(Note 2)

Factory Command List

Control Command (B2)	Function	Parameter (B3,B4)	Response Frame (B2)
0x00	Set device address	0x0000~0x00FF	B2=0x00 Nmal status B2=0x01 Frame error B2=0x02 Parameter error B2=0x03 Optocoupler error B2=0x04 Motor busy B2=0x05 Motor blocked B2=0xfe Task suspension B2=0xff Unknown error Note: B2=0xFE will only appears in RS485, at this moment you can only get response command by send polling command a0x4a or 00x4d
0x01	Set RS232 baud rate	0x0000~0x0004	
0x02	Set RS485 baud rate	0x0000~0x0004	
0x03	Set CAN baud rate	0x0000~0x0003	
0x07	Set maximum speed	1-255 (B) 0x0001~0x04b0 1~1200	
0x0b	Set reset speed	1-255	
0x10	Set CAN destination address	0x0000~0x00FF	
0x74	Set valve working current	0x0001~0x001E Refer to "Current Table"	

Current Table

Hexadecimal	Decimal	Current (A)	Hexadecimal	Decimal	Current (A)	Hexadecimal	Decimal	Current (A)
0x0001	1	0.1	0x000B	11	1.1	0x0015	21	2.1
0x0002	2	0.2	0x000C	12	1.2	0x0016	22	2.2
0x0003	3	0.3	0x000D	13	1.3	0x0017	23	2.3

0x0004	4	0.4	0x000E	14	1.4	0x0018	24	2.4
0x0005	5	0.5	0x000F	15	1.5	0x0019	25	2.5
0x0006	6	0.6	0x0010	16	1.6	0x001A	26	2.6
0x0007	7	0.7	0x0011	17	1.7	0x001B	27	2.7
0x0008	8	0.8	0x0012	18	1.8	0x001C	28	2.8
0x0009	9	0.9	0x0013	19	1.9	0x001D	29	2.9
0x000A	10	1.0	0x0014	20	2.0	0x001E	30	3.0

6. Operation Examples

Input correct address, command and parameter, ✓ at “Factory command”, when valve auto-reset after powered on takes into effect, users need to be restarted to make the setting effective.

E.g.1 Set device address

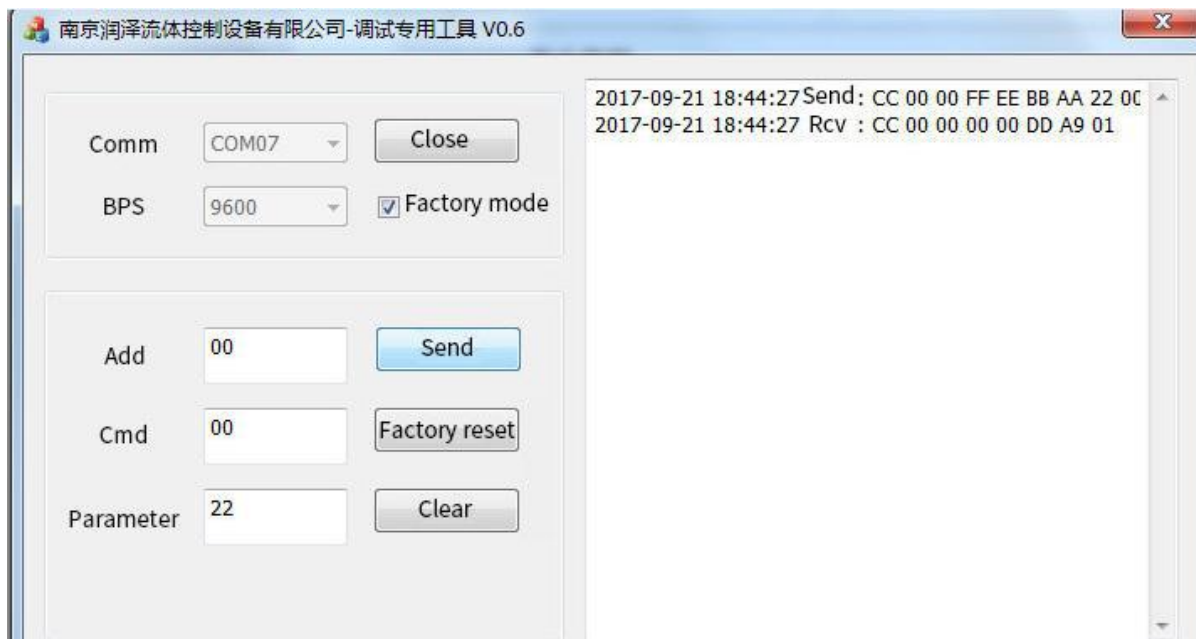

E.g. Set valve working current

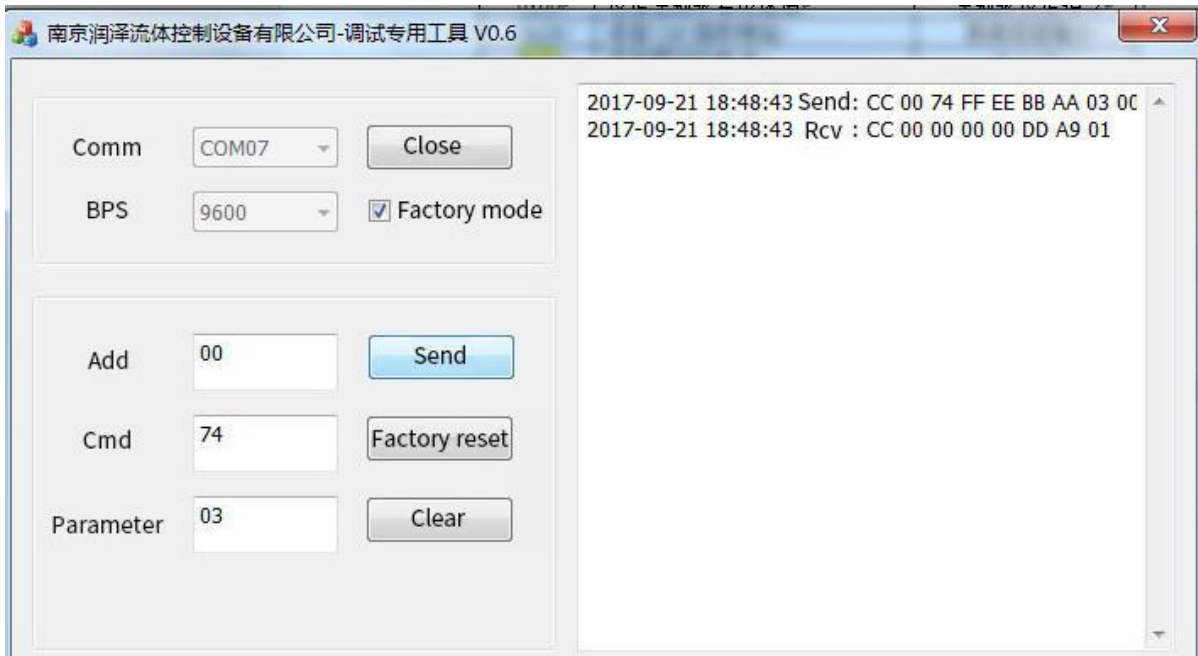

7. RS232 Debug Instructions

(1) RS232 Debug Tool: MotorTester V0.6.exe (contact customer service)

Since no RS232 communication interface on computer, we need to realize the communication by USB. Select the correct COM port from Device Manager on Computer, you need to verify which COM port is the correct one if there are few COM ports.



Factory default baud rate as 9600bps, after select correct COM port and baud rate, input correct command code B2 of Address, Command and Parameter, received parameter will be B3 B4. If you need to input factory command, then click "factory mode" while common command no need to tick this blank. Click "Send", the sent and received command show in the right display box.

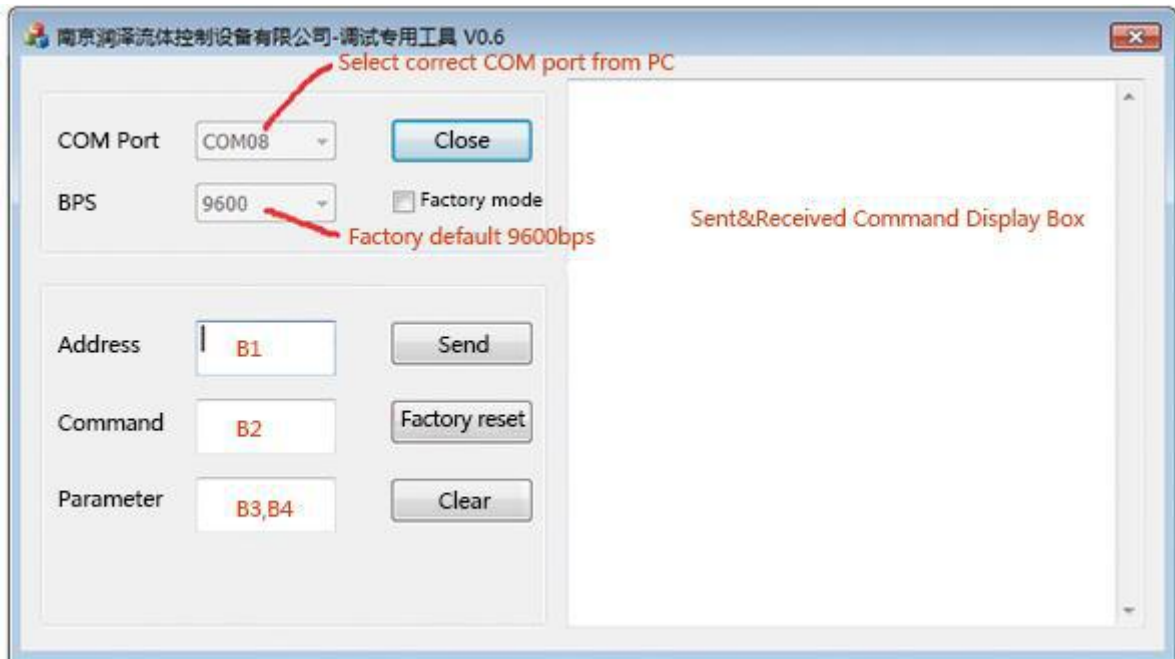

The button "clear" in debug tool means clear the contents in right display box; "factory reset" means return all the settings to factory default settings. Address, command, parameter must be input hexadecimal numbers.

(2) RS232 communication example

① Send Command: Set RS232 baud rate (Factory command)

B0	B1	B2	B3/B4/B5/B6	B7/B8/B9/B10	B11	B12	B13
0xCC	0x00	0x00	B3=0xFF B4=0xEE B5=0xBB B6=0xAA	B7=0x04 B8=0x00 B9=0x00 B10=0x00	0xDD	0x00	0x05

Response Command

B0	B1	B2	B3	B4	B5	B6	B7
0xCC	0x00	0x00	0x00	0x00	0xDD	0xA9	0x01

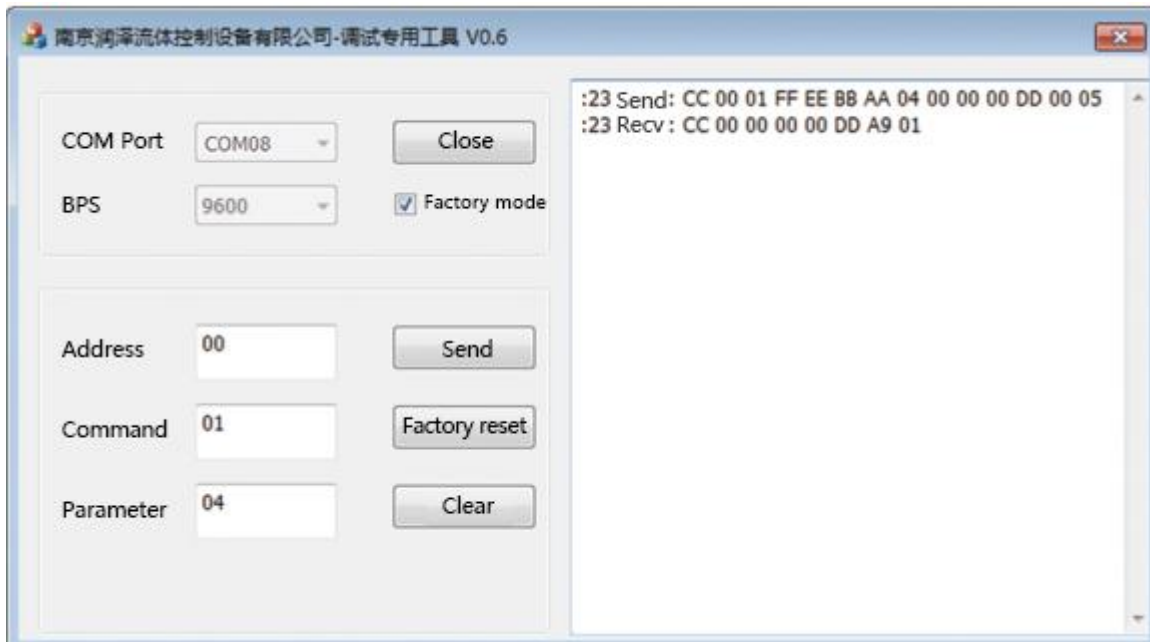

② Send common command: Query reset speed

B0	B1	B2	B3	B4	B5	B6	B7
0xCC	0x00	0x4a	0x00	0x00	0xDD	0xD4	0x01

Response command

B0	B1	B2	B3	B4	B5	B6	B7
0xCC	0x00	0x00	0xF9	0x05	0xDD	0xA7	0x02



8. RS485 Debug Instructions

(1) RS485 Debug tool: MotorTester V0.6.exe (contact customer service)

① Send command: Query motor status

B0	B1	B2	B3	B4	B5	B6	B7
0xCC	0x00	0x4a	0x00	0x00	0xDD	0xF3	0x01

Response command

B0	B1	B2	B3	B4	B5	B6	B7
0xCC	0x00	0x00	0xF9	0x05	0xDD	0xA7	0x02



② Send command: motor runs at clockwise and stops when touch reset Optocoupler

B0	B1	B2	B3	B4	B5	B6	B7
0xCC	0x00	0x42	0x10	0x27	0xDD	0x22	0x02

Response command

B0	B1	B2	B3	B4	B5	B6	B7
0xCC	0x00	0xFE	0x3B	0x22	0xDD	0x06	0x02

Send command "0x42", when set corresponding steps of parameter B3 B4 more than steps from current motor position to reset Optocoupler, then motor will stops at reset Optocoupler, parameter B3B4 = steps from current motor position to reset Optocoupler; when set corresponding steps of parameter B3 B4 less than steps from current motor position to reset Optocoupler, then motor will rotates as pre-set steps.



③ Send command: Motor runs at counterclockwise and stops when touch nether limit Optocoupler

B0	B1	B2	B3	B4	B5	B6	B7
0xCC	0x00	0x43	0x10	0x27	0xDD	0x23	0x02

Response command

B0	B1	B2	B3	B4	B5	B6	B7
0xCC	0x00	0x00	0xF9	0x05	0xDD	0xA7	0x02

Send command “0x43”, when set corresponding steps of parameter B3 B4 more than steps from current motor position to nether limit Optocoupler, then motor will stops at nether limit Optocoupler, parameter B3B4 = steps from current motor position to nether limit Optocoupler; when set corresponding steps of parameter B3 B4 less than steps from current motor position to nether limit Optocoupler, then motor will rotates as pre-set steps.



9. CAN Debug Instructions

(1) CAN Debug: CAN Test_Setup_V2.23.exe

Step 1. Choose baud rate

Step 2. Click “confirm”



Step 3. Click “start” and input command, or click “confirm and start CAN” in step 2 and input command. Input “frame ID”(address) and “data”, click “send”.

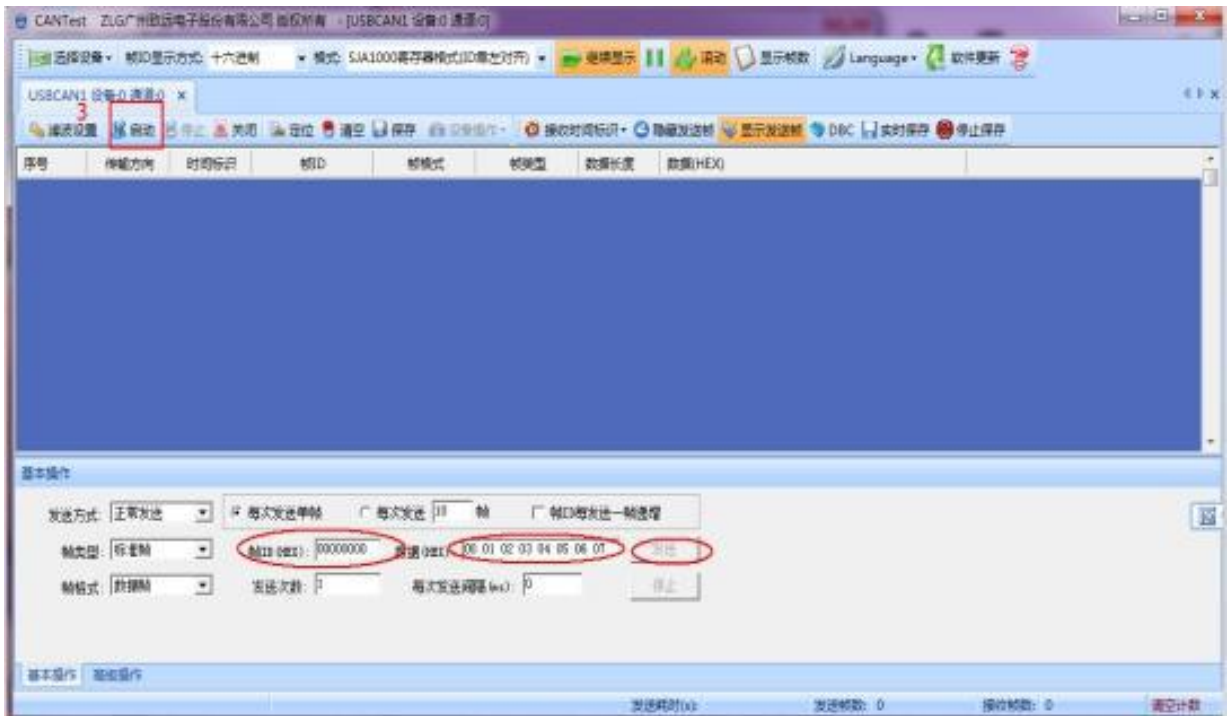

E.g. Query motor status by command 0x4a, the center display area show sent and received commands. When input command, other options such as send mode, frame type, frame format, send times etc. are usually keep them as default parameters.



(2) CAN communication example

① Send command: reset

B0	B1	B2	B3	B4	B5	B6	B7
0xCC	0x00	0x45	0x00	0x00	0xDD	0xEE	0x01

Response command

B0	B1	B2	B3	B4	B5	B6	B7
0xCC	0x00	0x00	0x00	0x00	0xDD	0xA9	0x01



Connection Fittings

Flanged Fittings	Pretighten Flangeless Fittings	Flangeless Fittings
Material PP/PTFE (medical grade)	Material PP/PTFE (medical grade)	Material PP/PTFE (medical grade)
Certification RoHs	Certification RoHs	Certification RoHs
Thread 1/4-28UNF/M6	Thread 1/4-28UNF/M6	Thread 1/4-28UNF/M6
Tubing OD1.6/2.0/2.5/3.0/3.175/3.2/4.0mm	Tubing OD1.6/2.0/2.5/3.0/3.175/3.2mm	Tubing OD1.6/2.0/2.5/3.0/3.175/3.2mm

Packing Info.

Carton Size: 43*21.5*27.5CM

G.W.: 5.5KG



Nanjing Runze Fluid Control Equipment Co.,Ltd
 No.9 Tianxing West Road Dongshan Street Jiangning District
 Nanjing City, Jiangsu Province, China
 Mobile: +86 17366384502
 Email: min.zhu@runzeliuti.com
 Contact: Julie Zhu