

润泽流体 Runze Fluid

Nanjing Runze Fluid Control Equipment Co., Ltd is a high-tech enterprise who devote ourselves to research and develop high precision analytical parts such as syringe pumps, multiport valves, plastic fittings, peristaltic pumps, gastight syringes, customized dispensing systems that play an important role in medical analysis instruments, environmental on-line analyzers, industrial production line, laboratory and biological analyzers.



Version 2.1

SV-06 Multiport Selector Valve User's Manual



南京润泽流体控制设备有限公司

润泽流体
Runze Fluid

NANJING RUNZE FLUID CONTROL EQUIPMENT CO.LTD

Thank you very much for choosing our product. Please read and keep this manual carefully before use.

Table of Contents

Chapter 1 Overview	3
1.1 Company Profile	3
Chapter 2 Technology and Function	3
2.1 Product Features	4
2.2 Naming Rules	4
2.3 Product Specification	5
2.4 Structure Dimensions (unit: mm)	5
2.5 Technical Parameters	7
2.6 Flow Configuration	8
2.7 Reset Status	8
2.8 Port Definition	9
Chapter 3 Description of Control Code	10
3.1 Overview	10
3.2 Installation and Debugging	10
3.3 Code Instructions	10
3.3.1 Common Command Format (send 8 bytes, return 8 bytes)	10
3.3.2 Factory Command Format (send 14 bytes, return 8 bytes)	13
Chapter 4 Technical Service	16

Chapter 1 Overview

1.1 Company Profile

Nanjing Runze Fluid Control Equipment Co., Ltd. was established in 2014. We are a national high-tech enterprise focusing on R&D and production of fluid accessories for numerous analytical instruments. We engineer, manufacture and market differentiated standard products such as syringe pumps, selector valves, high-pressure valves, gastight syringes, peristaltic pumps, plastic fittings, etc.. We persevere in providing our customers with best quality and service in the fields of environmental monitoring, biopharmaceuticals, medical equipment, industrial automation and laboratory instruments, etc..

In past years, we have accumulated rich technical and practical experience that bring us honors of ISO9001, National High-tech Enterprise, Jiangsu Province Private Science and Technology Enterprise, 5A Bank Credit Assessment, 38 technical patents and multiple software copyright including 8 invention patents, 17 utility model patents, 13 design patents.

Runze always focuses on strategy and innovation, accurately grasps the general trend of the fluid equipment industry, and has made continuous and large R&D investment in the core technology. This has enabled the company to obtain a huge advantage in the production and sales of analysis instrument accessories and is always at the forefront of the industry. RUNZE Technology Center has a reliable EMC laboratory and a series of advanced processing equipment and testing instruments, such as imported white light interferometer, Keens plane rapid detector, five-axis machining center, high-precision nano-grinding machine, etc.. Runze adopts leading production technology, fully implement lean production concepts, and always maintain professional international first-class manufacturing capabilities.

Chapter 2 Technology and Function

2.1 Product Features

(1) Name: The multiport selector valve is an electric selector valve independently developed by RUNZE Fluid Control Equipment Co., Ltd., also known as electric rotary valve;

(2) Control: The selector valve integrates motor control circuit. By receiving instructions from the host computer to control the operation of the stepper motor to make the rotor turn to the specified hole position to achieve the switching of the flow path. Serial communication protocol supports RS232/RS485/CAN bus.

(3) Corrosion Resistance: This type of selector valve adopts sapphire valve core, which can be applied to various corrosive liquid. The valve head is made of PCTFE (polychlorotrifluoroethylene) and stainless steel 304, maintenance-free and the liquid is not in contact with the stainless steel.

(4) Valve Core Structure: The valve core adopts a multi-directional self-adaptive plane fitting method, which can extend the service life of the product effectively. (This structure has been applied for utility patent, patent number: CN204852471U)

(5) Motive Power: The rotation of the valve body adopts the imported NMB planetary gearbox motor as the power plant, which is extremely reliable.

(6) Orientation: The valve hole is oriented by optocoupler of code disc, which can effectively solve the problem of inaccurate positioning after the gearbox is worn down.

(7) Drive: The drive module adopts a low-power drive chip. It can effectively reduce the heat generated when the chip is running which affects performance.

(8) Control Unit Interface: XH terminal with 2.54mm pitch.

(9) Mechanical Interface: 1/4-28UNF female thread.

(10) Usage: Widely used in the collection and distribution of fluid samples.

(11) Application: Environmental testing devices, experimental analysis instruments, medical analyzers, chromatographic instruments, etc.

Note: Before using the selector valve, please read the "Instruction Manual" carefully and follow the provisions in it.

2.2 Naming Rules

The model parameters are as follows:

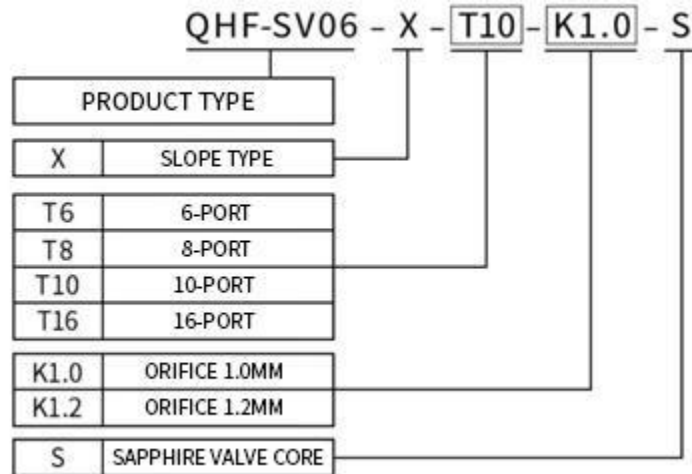

For example: slope type 6-port sapphire selector valve is named as QHF-SV06-X-T6-K1.2-S.

2.3 Product Specification

The SV-06 selector valve can be divided into 6-port, 8-port, 10-port, 12-port and 16-port according to the number of ports.

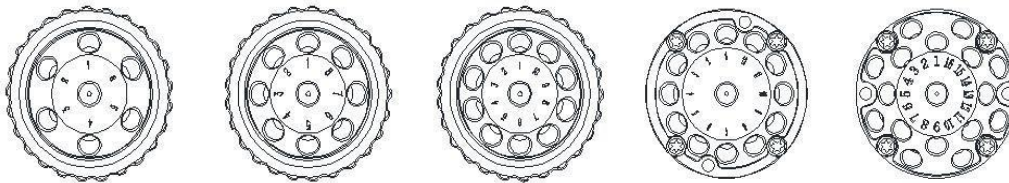

Figure 2-3-1

The 6/8/10-port can be installed in place of other selector valves of RUNZE . The size of the mounting plate is shown in Figure 2-3-2 (unit: mm).

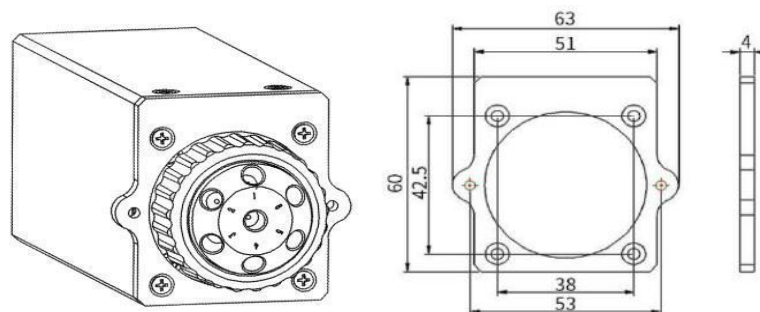
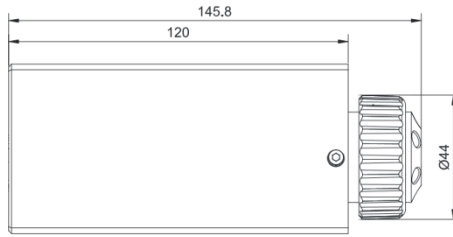
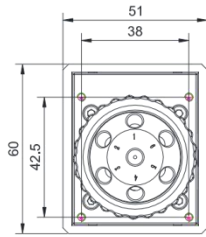
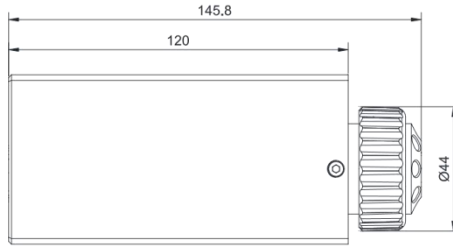
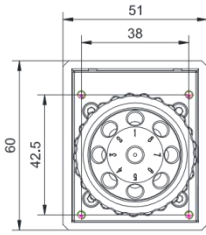

Figure 2-3-2

2.4 Structure Dimensions (unit: mm)



6 ports



8 ports

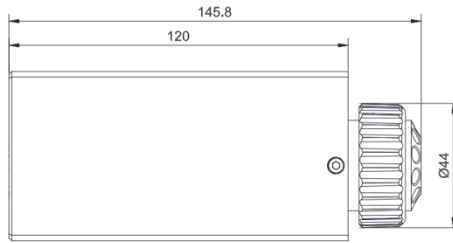
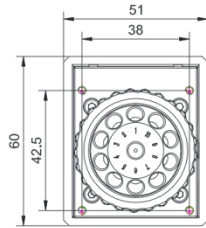

10 ports

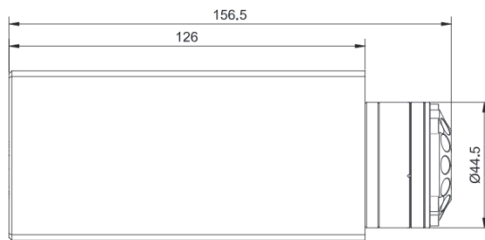
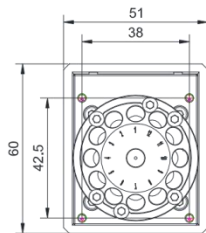

12 ports

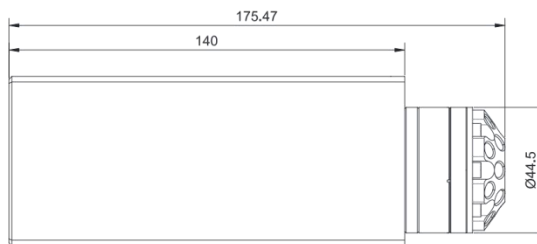
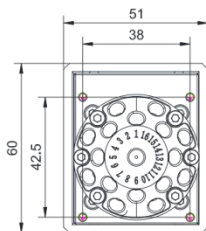

16 ports

2.5 Technical Parameters

Description	Parameter		
	6/8/10 ports	12 ports	16 ports
Configuration	6/8/10 ports	12 ports	16 ports
Orifice	1.2 mm	1.0 mm	1.0 mm
Dead volume (port to port)	27.5 μ L	22.43 μ L	33.68 μ L
Dead volume (sealed rotor)	5.41 μ L	6.08 μ L	10.4 μ L
Wetted material	UPE, Sapphire		
Pressure rating	0-1.0Mpa (air)/ 0-1.6Mpa (water)		
Origin detection	Automatically detect the initial position when power on.		
Liquid temperature	0C° ~ 150C°		
Connection	1/4-28UNF female thread		
Replaceable part	Stator replaceable and sealed rotor irreplaceable		
Transposition	Random start to any specific port		
Drive	Non-optional		
Switching time	\leq 5s/circle		
Communication	RS232/RS485/CAN bus		
Maximum drive force/torsion	2.6N/m	3N/m	3.5N/m
Secondary drive force/torsion	0.32N/m	0.36N/m	0.42N/m
Baud rate	RS232/ RS485: 9600bps, 19200bps, 38400bps, 57600bps, 115200bps CAN: 100kbps, 200kbps, 500kbps, 1Mbps		
Address& Parameter setting	Via communication		
Power supply	DC24V/3A		
Maximum power	60W		
Working temperature	-10C° ~ 50C°		
Working humidity	\leq 80% (relative humidity, non-condensing)		
Dimension (L*W*H)	60x51x145.8mm	60x51x156.5mm	60x51x175.5 mm
Weight	0.73kg	0.86kg	1.02kg
Please consult for other special requirements.			

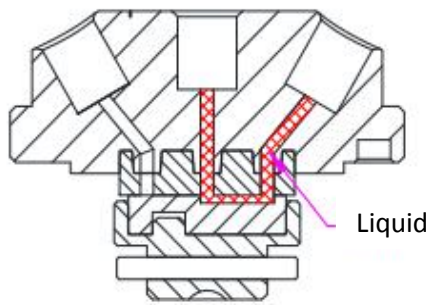

Figure 2-5-1 Dead volume (port to port)

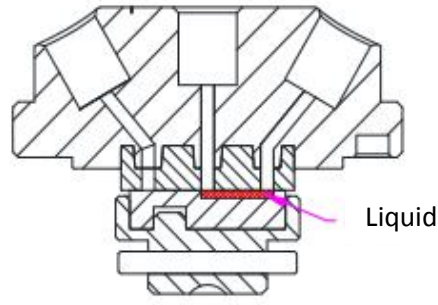
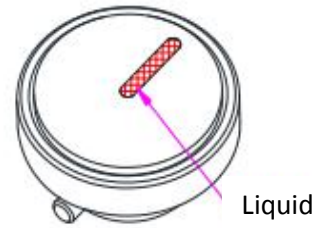

Figure 2-5-2 Dead volume (sealed rotor)



2.6 Flow Configuration

Center port is the common port and the valve can switch to any specific port by rotor. Flow configuration is shown in Figure 2-6.

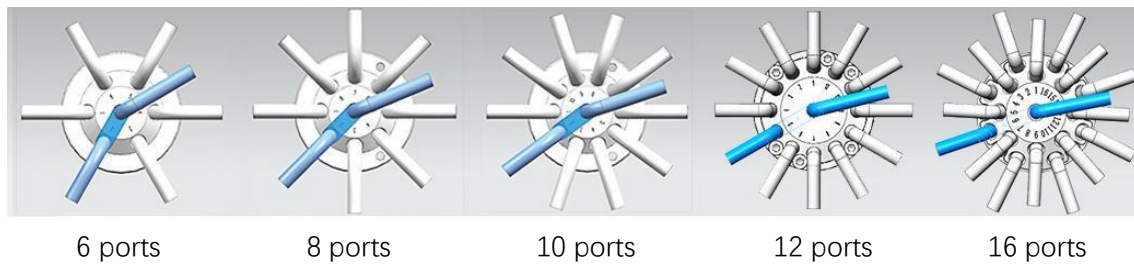

Figure 2-6

2.7 Reset Status

Reset direction is counterclockwise (unchangeable). After reset, the rotor slot is between the port 1 and the port of the maximum number. At this time, the center port and other ports are disconnected, as shown in Figure 2-7.

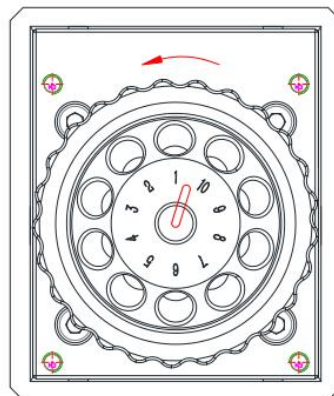

Figure 2-7

2.8 Port Definition

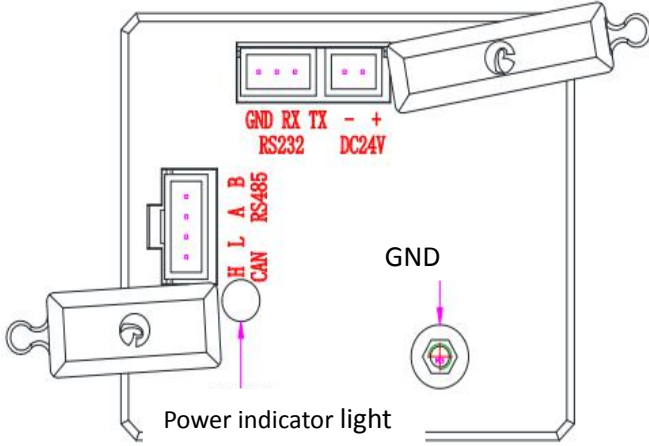

Figure 2-8 Port diagram

Port	Description
+	DC24V positive
-	DC24V negative
TX	RS232 data input
RX	RS232 data output
GND	GND
H	CANH
L	CANL
A	RS485 A
B	RS485 B

Port definition of drive board

Chapter 3 Description of Control Code

3.1 Overview

The data transmission between the selector valve and the host device (computer, single-chip computer, PLC, etc.) adopts serial communication (eg. RS-232/RS-485/CAN bus) and the following describes the communication format. The communication adopts asynchronous serial communication. Commands and data frames use sum check, and the sum check is two bytes (2 bytes). Commands and data in communication are in hexadecimal, and parameters are stored in little-endian mode.

Communication interface: RS-232, RS-485, CAN bus;

Communication mode: two-way asynchronous, master-slave mode;

Baud rate: RS232, RS485: 9600bps, 19200bps, 38400bps, 57600bps, 115200bps

CAN: 100Kbps, 200Kbps, 500Kbps, 1Mbps

Data bit: 8 bit

Parity: no check

Response time: <1 second

3.2 Installation and Debugging

1. Cable connection (including power supply and communication line) (see Figure 8 above);
2. Installation and debugging tools, see 《Instructions for Debugging Tools》 for details.
3. Instructions for use, see 《Quick Use Guide》 for details.

3.3 Code Instructions

3.3.1 Common Command Format (send 8 bytes, return 8 bytes)

Byte send:

B0	B1	B2	B3	B4	B5	B6	B7
FH (frame header)	Address code	Function code	Status parameter		EOF (end of frame)	Cumulative sum	
STX	ADDR	FUNC	1-8 bit	9-16 bit	ETX	Low byte	High byte

- The 1st byte STX : Frame header (CCH)
- The 2nd byte ADDR : Slave address (0x00 ~ 0xFF)
- The 3rd byte FUNC : Function code
- The 4th, 5th byte : Parameters corresponding to the function code
- The 6th byte ETX : End of frame (DDH)
- The 7th, 8th byte : Cumulative sum check code from byte 1 to 6

Byte return:

B0	B1	B2	B3	B4	B5	B6	B7
FH (frame header)	Address code	Status code	Status parameter		EOF (end of frame)	Cumulative sum	
STX	ADDR	FUNC	1-8 bit	9-16 bit	ETX	Low byte	High byte

- The 1st byte STX : Frame header (CCH)
- The 2nd byte ADDR : Slave address (0x00 ~ 0xFF)
- The 3rd byte FUNC : Status code
- The 4th, 5th byte : Parameters corresponding to the function code
- The 6th byte ETX : End of frame (DDH)
- The 7th, 8th byte : Cumulative sum check code from byte 1 to 6

Common command

Item	Command/ Code (B2)	Description	Parameter (B3, B4)	Response parameter (B3, B4)
Query command	0x21	Query RS232 baud rate	0x0000	Totally 5 baud rates: the factory default is 9600bps. (B4=0x00) B3=0x00 corresponding baud rate is 9600bps B3=0x01 corresponding baud rate is 19200bps B3=0x02 corresponding baud rate is 38400bps B3=0x03 corresponding baud rate is 57600bps B3=0x04 corresponding baud rate is 115200bps
	0x22	Query RS485 baud rate	0x0000	
	0x23	Query CAN baud rate	0x0000	Corresponding CAN baud rate: B3B4=0x0000 100Kbps B3B4=0x0001 200Kbps B3B4=0x0002 500Kbps B3B4=0x0003 1Mbps

	0x2e	Query automatic reset when power on	0x0000	(B4=0x00) B3=0x00 indicates not automatic reset when power on. B3=0x01 indicates automatic reset when power on.
	0x30	Query CAN destination address	0x0000	B3=0xXX (B4=0x00) The value range of XX is 00 ~ FF, and the default is 00.
	0x3e	Query current port position	0x0000	B3B4 the current position of code disc
	0x3f	Query current firmware version	0x0000	B3B4 software version number, in hexadecimal
Control Command	0x44	The motor rotates through the code disc and selects the optimal path automatically.	Port number (port1-max. port)	RS232 : B2=0x00, B3B4 is internal data and appears randomly RS485: B2=0xFE, B3B4=0x0000
	0x45	Reset	0x0000	RS232 : B2=0x00, B3B4 is internal data and appears randomly. RS485: B2=0xFE, B3B4=0x0000
	0x49	Stop forcibly	0x0000	B3B4 remaining steps
	0x4a	Query motor status	0x0000	B3B4=0x0000

Status list

Item	Status (B2)	Description of the response frame (B2) status
Response status	0x00	Normal status
	0x01	Frame error
	0x02	Parameter error
	0x03	Optocoupler error
	0x04	Motor busy
	0x05	Motor stalled
	0x06	Unknown location
	0xfe	Task being executed
	0xff	Unknown error

Note: In 485 communication, when sending an action command, the B2 byte in the response frame is FE, indicating that the command is received and is being executed.

3.3.2 Factory Command Format (send 14 bytes, return 8 bytes)

Factory commands need to be used with V0.6 debugging tools when RS232 or RS485 are used separately. See 《Quick Use Guide》 in detail.



Byte send:

B0	B1	B2	B3,B4,B5,B6	B7	B8	B9	B10	B11	B12	B13
FH (frame header)	Address code	Function code	Pass word	Function parameter				EOF (end of frame)	Cumulative sum	
STX	ADDR	FUNC		1-8 bit	9-16 bit	17-24 bit	25-32 bit	ETX	Low byte	High byte

The 1st byte STX: Frame header (CCH)

The 2nd byte ADDR: Slave address (0x00 ~ 0xFF)

The 3rd byte FUNC: Function code

The 4th -7th byte: Factory command format

The 8th -11th byte: Parameters corresponding to the function code

The 12th byte ETX: End of frame (DDH)

The 13th, 14th byte: Cumulative sum check code from byte 1 to 12

Byte return:

B0	B1	B2	B3	B4	B5	B6	B7
FH (frame header)	Address code	Function code	Status parameter		EOF (end of frame)	Cumulative sum	
STX	ADDR	FUNC	1-8 bit	9-16 bit	ETX	Low byte	High byte

The 1st byte STX: Frame header (CCH)

The 2nd byte ADDR: Slave address (0x00 ~ 0xFF)

The 3rd byte FUNC: Status code

The 4th -5th byte: Parameters corresponding to the function code

The 6th byte ETX: End of frame (DDH)

The 7th, 8th byte: Cumulative sum check code from byte 1 to 6

Factory Command/Status List

Item	Command/Status (B2)	Description	Operation command (B3, B4) Value range	Description of corresponding parameter
Factory command	0x00	Set device address	0x0000~0x00FF	Address: 0~255
	0x01	Set RS232 baud rate	0x0000~0x0004	Totally 5 baud rates: the factory default is 9600bps (B4=0x00) B3=0x00 corresponding baud rate is 9600bps B3=0x01 corresponding baud rate is 19200bps B3=0x02 corresponding baud rate is 38400bps B3=0x03 corresponding baud rate is 57600bps B3=0x04 corresponding baud rate is 115200bps
	0x02	Set RS485 baud rate	0x0000~0x0004	
	0x03	Set CAN baud rate	0x0000~0x0003	Corresponding CAN baud rate: B3B4=0x0000 100Kbps B3B4=0x0001 200Kbps B3B4=0x0002 500Kbps B3B4=0x0003 1Mbps
	0x0E	Set automatic reset when power on	0x0000~0x0001	B3B4=0x0000 indicates not automatic reset when power on B3B4=0x0001 indicates automatic reset when power on
	0x10	Set CAN destination address	0x0000~0x00FF	Address: 0~255

Note: (1) The code B2 in the response command indicates the current running status of the motor. Only when B2=0x00, the motor is in normal operation, and other parameters are shown in the above table, corresponding to different abnormal status respectively. In principle, the motor should be send the 0X4A command to query the motor status at the end of the motor operation. Only when the B2 parameter in the response command is 00, other commands can be executed correctly.

Note: The code parameters of all the above commands are set in little-endian mode. Low data is stored in the low bit of the address and high data is stored in the high bit of the address.

Product safety precautions:

- Please ensure that the voltage matches with the standard voltage of the instrument.
- Please use the original serial cable of this product to connect to the power supply.
- The three communication methods (RS232, RS485, CAN bus) of this product are in non-isolated mode; not hot-plug.
- Please cover the unused ports with suitable coned plugs when laid aside to avoid impurity substance and air.
- Do not disassemble the product parts at will. No warranty for tamper-evident label tearing.
- When operating the software, please refer to the operating instructions of the software and the communication protocol, and data input is not allowed to be fabricated without authorization.
- When using CAN bus protocol to connect multiple devices, please refer to the connection method shown in Figure 4-1 below.

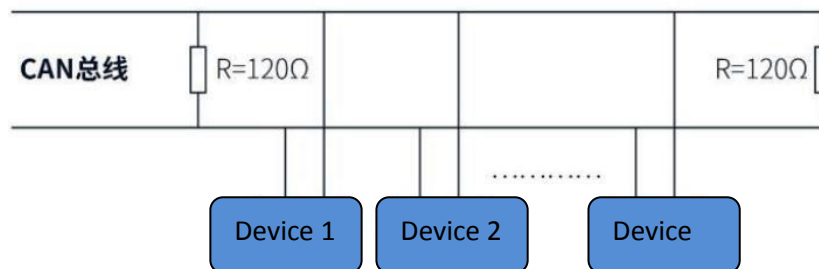

Figure 4-1

- When using RS485 protocol to connect multiple devices, please refer to the connection method shown in Figure 4-2 below. But the resistance value is determined by the number of devices connected by the user.

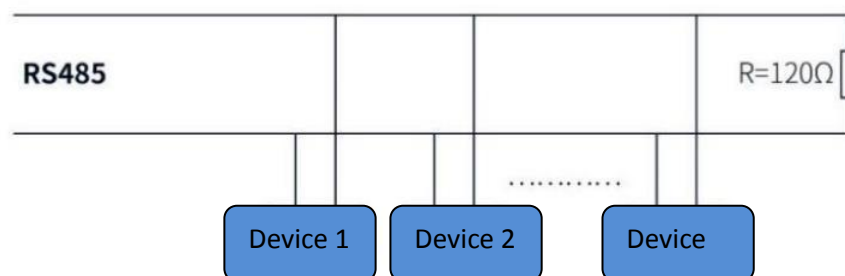

Figure 4-2

Chapter 4 Technical Service



Tel : 025-51197362

Phone : 138 5195 4068

Fax : 025-51197362

Technical support : 183 5195 5944

Official URL : <http://www.runzefluid.com>

Alibaba Store URL : <https://runzeliuti.en.alibaba.com>

Sales Email : xiaoyan.xiang@runzeliuti.com

Address : NO.9 Tianxing West Road, Dongshan Street, Jiangning District,
Nanjing, Jiangsu, China



Official URL



Alibaba Store URL



Aliexpress Store URL